

## Axially split volute casing pumps

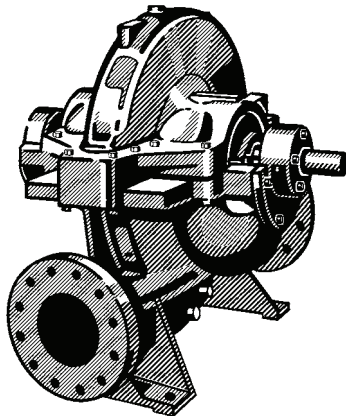

Omega

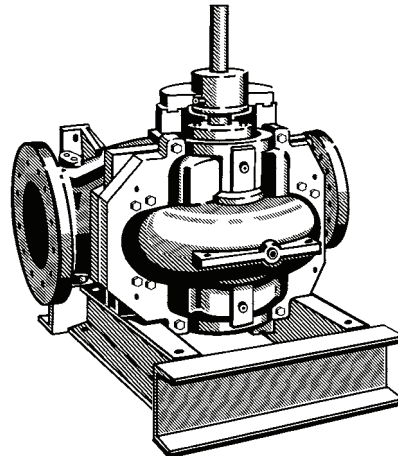

Omega V

### Automation products available:

- PumpExpert
- Hyamaster
- hyatronic

## Applications

Waterworks, irrigation and drainage pumping stations, power stations, industrial water supply systems, fire fighting systems, marine applications as well as general applications in refineries.

## Operating data

Pump sizes	DN 80 up to 350	(3...14 in)
Capacities	Q up to 800 l/s	(12.328 US.gpm)
Total heads	H up to 170 m	(558 ft)
Operating pressure	p up to 25 bar	(363 psi)
Operating temperature	t up to +105 °C	(221 °C)

## Design

Single stage, axially split volute casing pump with double-entry radial impeller, for horizontal or vertical installation. Installation of the horizontal drive either on the left or right side of the pump (optional). Flanges drilled to ISO, DIN, BS or ANSI.

## Designation

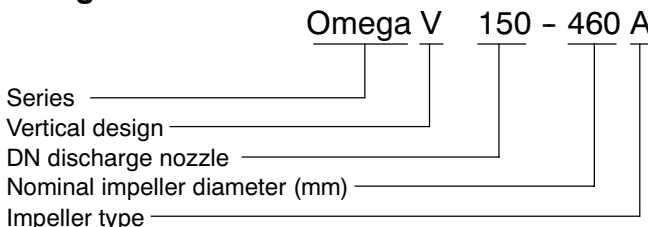

## Bearings

**Omega:** on both sides grease-lubricated, maintenance-free, deep groove ball bearings, sealed for life,

**Omega V:** top: grease-lubricated, maintenance-free, deep groove ball bearing, sealed for life  
bottom: wear-resistant, medium-lubricated plain bearing of silicon carbide (Residur<sup>®</sup>).

## Shaft seal

Uncooled soft-packed stuffing box or uncooled, single-acting, unbalanced bi-directional mechanical seal acc. to DIN 24960.

With an operating pressure > 16 bar: mechanical seal, balanced by hydraulic means.

## Materials

Volute casing:	Cast iron	JL 1040 (GG-25)
	Ductile cast iron	JS 1030 (GGG-40)
	Ni-Resist	GGG-NiCrNb 202
	Duplex steel	1.4517 / 1.4593
Impeller:	Bronze	G-CuSn10
	Duplex steel	1.4517 / 1.4593
Shaft:	Chromium steel	1.4021
	Duplex steel	1.4462
Casing wear rings:	Bronze	GZ-CuSn7ZnPb
	Duplex steel	1.4470

**Selection charts**

(higher speeds, with the pumps driven by a Diesel unit, available upon request)

**n = 2900 1/min**     $\sqcap$  =  $\eta_{opt}$  A - Impeller  
                               + =  $\eta_{opt}$  B - Impeller

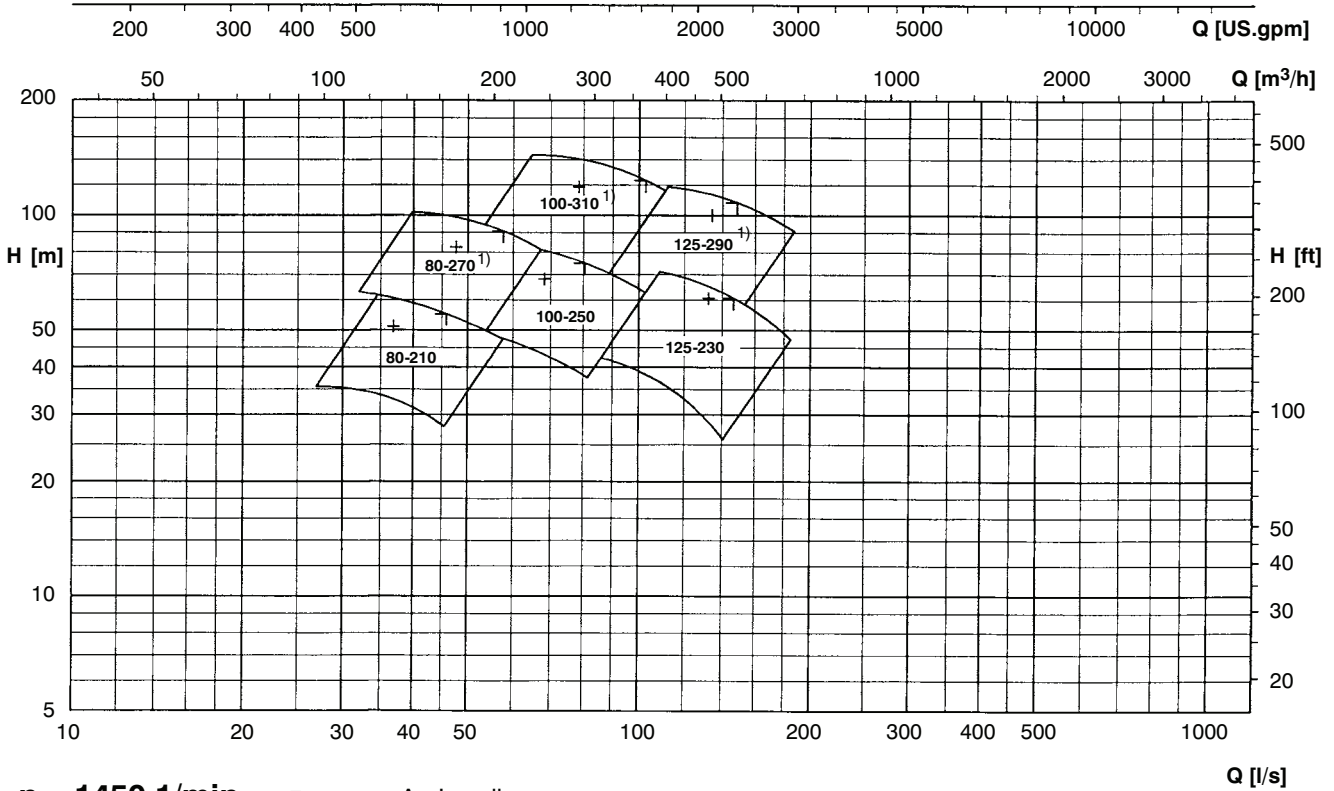

**n = 1450 1/min**     $\sqcap$  =  $\eta_{opt}$  A - Impeller  
                               + =  $\eta_{opt}$  B - Impeller  
                               ○ =  $\eta_{opt}$  C - Impeller

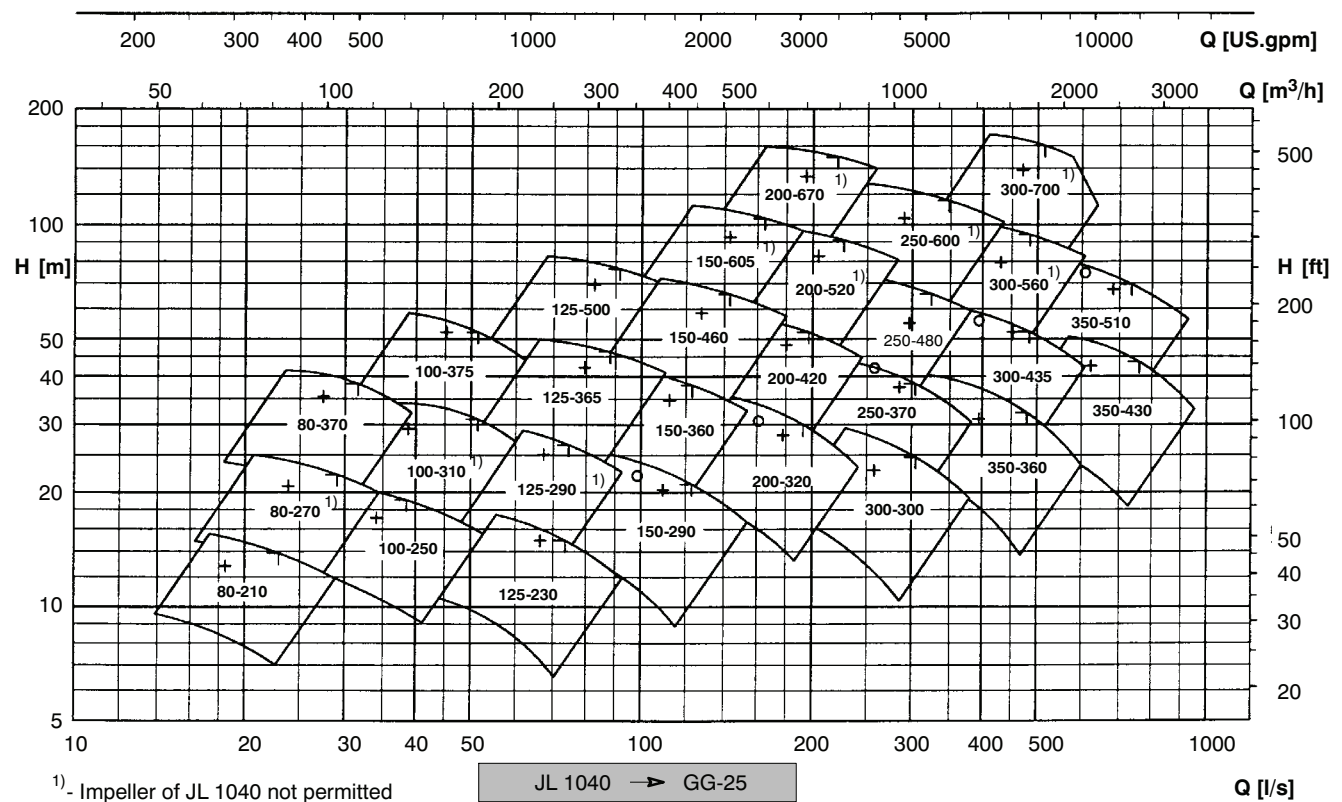

<sup>1)</sup> - Impeller of JL 1040 not permitted

JL 1040 → GG-25

**Your technical advantages**

**Your service advantages**

**Innovative casing**

- in-line design
- short distance between bearings and correspondingly short shaft
- leak-tight due to compact joint flange with long, prestressed bolts
- counter-rotation possible with the same parts
- double-volute version for appropriate total heads
- upper casing self-aligning and, therefore, easy to mount

**High-performance impeller**

- minimal axial thrust due to double-entry impeller
- impeller wear rings optional
- new vane passage with excellent hydraulic characteristics

**Service-friendly shaft**

- completely sealed and dry for zero corrosion
- short and rigid with negligible vibrations
- replaceable shaft protecting sleeves
- no threads exposed to pumped medium, i.e. long operating life and no corrosion
- adjustment-free assembly
- quick and easy assembly/dismantling of the rotor components due to elastically prestressed mountings

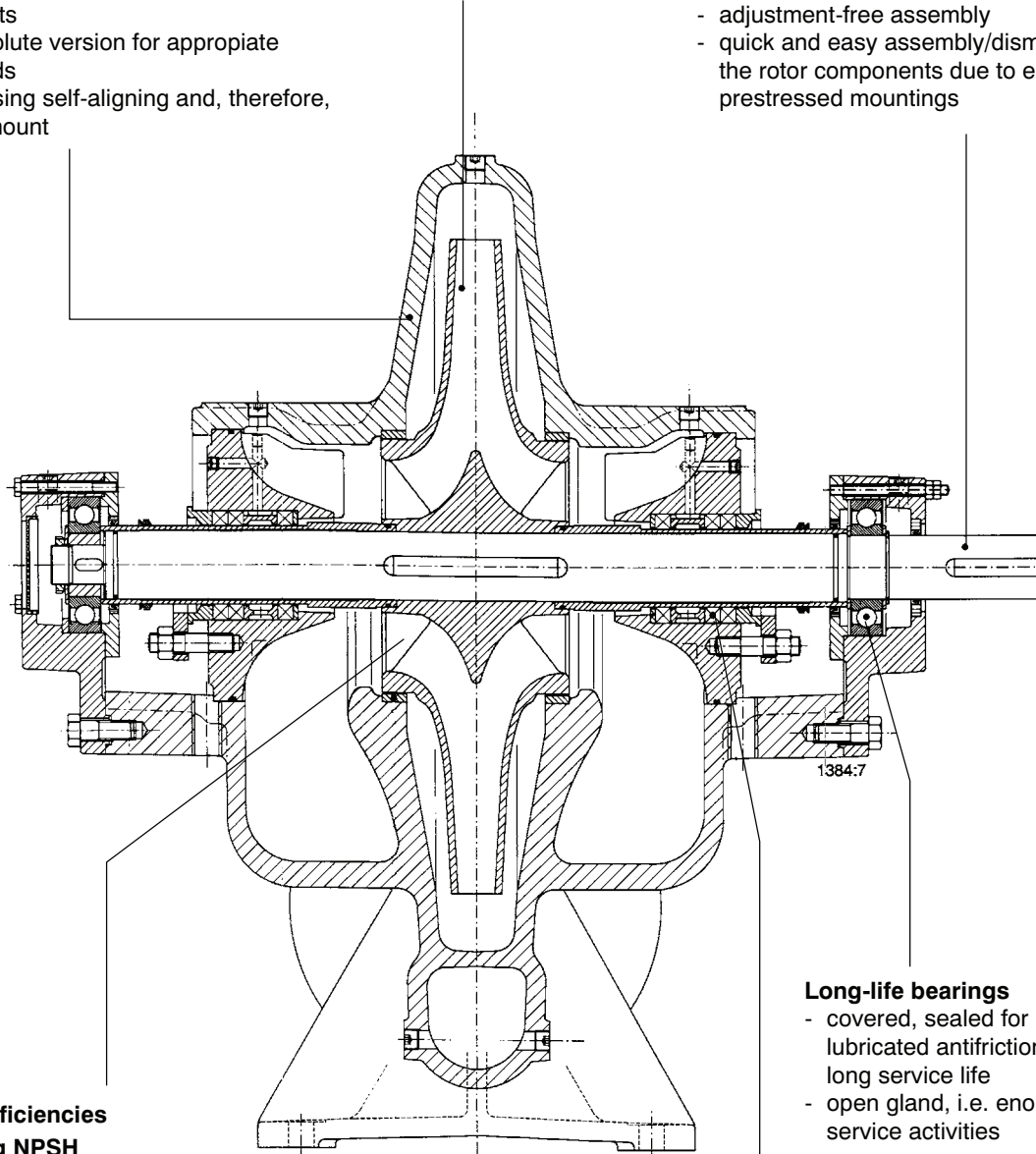

**Excellent efficiencies**

**Outstanding NPSH**

- computer-optimized double-entry impellers
- smooth surfaces inside the casing and on the impeller
- smooth, quiet running also guaranteed by a large impeller eye area
- no drop in efficiency due to cost-effective, replaceable casing wear rings and impeller wear rings
- smooth, low-wear running due to a swirl-free, low-energy loss inlet

**Long-life bearings**

- covered, sealed for life, grease-lubricated antifriction bearings for a long service life
- open gland, i.e. enough space for service activities

**Application-orientated seals**

- asbestos-free, potable-water quality soft-packed stuffing boxes
- or bi-directional mechanical seals

**Contents**

	Page
General remarks:	
- Scope of supply	
- Packing and shipment	
- Guarantee, testing and quality control	
- Order data for pump and motor	
- Sales program and accessories	5 - 6
Types of arrangement, directions of rotation, flow directions	7
Materials / application limits, pressure limits and material combinations, recommended material combinations (table of pumped media)	8 - 9
Technical data	10
Speeds, vibrations, coatings	11
Arrangement of sealing water and flushing pipes, vent connections and bearing temperature sensors	12
General drawings	13 - 14
Mechanical seals, standard design	15
Tables of dimensions and weights (pump)	16- 23
Arrangement drawings horizontal, vertical	24 - 49
Recommended spare parts	50 - 52
Motor dimensions and weights ( Type of arrangement 3E )	53

## Scope of supply

Pump supplied with bare shaft end, in horizontal or vertical design, painted to KSB standard, sealed by a soft-packed stuffing box or by a mechanical seal.

Add-on components to convert the pump to a complete pump / motor set:

Pump to be supplied with:

- common baseplate / base frame for pump and motor (for horizontal installation)
- motor stool and foot for vertical installation (including support feet in case of the larger motor sizes)
- motor
- coupling and coupling guard

Accessories:

- sealing water and / or flush pipe
- complete set of pressure gauges
- cyclone separator including the necessary piping
- vent valve (for manual or automatic operation)
- temperature sensor for anti-friction bearings (PT 100)
- limit value sensor switch for PT 100

## Packing and shipment

### Omega horizontal:

Up to a total weight of 1500 kg or a motor size IEC 280, the units (consisting of pump, motor, coupling and coupling guard) are supplied completely assembled and mounted on a common baseplate / common base frame. Units weighing > 1500 kg, or comprising a motor size IEC 315 and larger are completely assembled at the factory to check the components for correct adjustment, subsequently disassembled again and each major component is packed separately for shipment.

### Omega V vertical:

Omega V vertical pumps are dispatched with the motor stool mounted. The motors themselves are packed separately.

## Guarantee, testing and quality control

Every pump is tested for correct functioning. The operating data are guaranteed **without** acceptance test in accordance with ISO 2548 C, DIN 1944/III or comparable international testing standards. Acceptance tests in accordance with ISO / DIN standards can be provided against an extra charge.

The quality of the Omega products is ensured by a tested and certified quality assurance system according to DIN ISO 9001 / EN 29001.

## Order data

### - pump:

- description of the pump according to "Designation"
- capacity Q
- total head H (  $H_{geo}$  and plant losses )
- material combination
- mating dimensions of flanges
- shaft seal soft packed stuffing box or a mechanical seal
- liquid handled and liquid temperature (see fig. pg. 7)
- accessories required
- number of copies and language of operating manual

### - motor:

#### (choice by KSB)

- type of construction
- type of enclosure
- voltage, frequency, method of starting
- ambient temperature
- insulation class
- accessories required

### motor:

(motor to be supplied by the customer)

**Each order has to be accompanied by a binding motor dimension table and a data sheet indicating the effective speed and weight of the motor. This information has to be supplied by the client without exception!**

**Sales program and accessories**

	Scope of supply / Characteristics	Omega		Omega V		
		Fig. 0	3E	DB	DK	DJ
Motor	without motor	●	● <sup>1)</sup>	●	●	●
	KSB standard motor	-	● <sup>1)</sup>	●	●	Δ
	Proprietary product to client's choice (IEC-standard up to 315 M)	-	○	○	○	Δ
	Motor not in accordance with IEC 72 (315 L and above)	-	Δ	Δ	Δ	Δ
Installation set <sup>2)</sup>	Baseplate / base frame	-	●	-	-	-
	Foot / rail	-	-	-	-	●
	Motor stool and foot (incl. support foot) <sup>2)</sup>	-	-	●	●	-
	Universal joint shaft, motor stool	-	-	-	-	Δ
	Coupling and coupling guard	-	●	●	●	-
Accessories (optional)	Sealing water and flush pipes <sup>3)</sup>	○				
	Complete set of pressure gauges (to ZN 16064)	○				
	Cyclone separator with piping	○				
	Vent valve (manual or automatic)	○				
	Temperature sensor for anti-friction bearings (PT 100)	○				
	Limit value sensor switch suitable for PT 100 (one for each PT 100)	○				
	Drain	○				
Shaft seal	Soft-packed stuffing box	●				
	Mechanical seal (standard mech. seal to DIN 24960)	●				
	Mechanical seal, balanced (when working pressure > 16 bar)	○				
Paint	to KSB standard	●				
	with a coat of primer to KSB standard only	○				
	internal coat of paint (approved for drinking water applications)	○				
	complete coating system to customer specification	Δ				
	top coat (on a base coat of standard primer) to customer specification	Δ				
Flange	to DIN EN 1092-2 / BS 4504	●				
	to ANSI B 16.1	○				
Acceptance testing	acc. to KSB standard (i.e. ZN 56535)	●				
	to DIN 1944/III	○				
	to DIN 1944/II	○				
	to ISO 2548 C	○				
	to BS 5316 P1/P2	○				
	other acceptance test (check-back required)	Δ				

- 1) motor adjustable for height  
 2) varies according to motor size  
 3) not required with an inlet pressure of p > 2 bar (Arrangement, see p. 12.)

●	<b>standard version</b>
○	<b>standard variant</b>
Δ	<b>special version</b>
<b>Standard variants and special versions are subject to surcharge and require longer delivery times</b>	

**Types of arrangement**

**Horizontal**

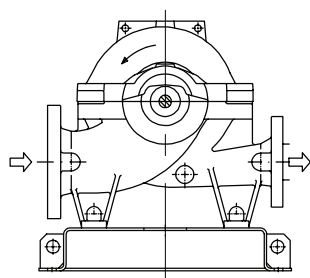

**Type of arrangement 3E**

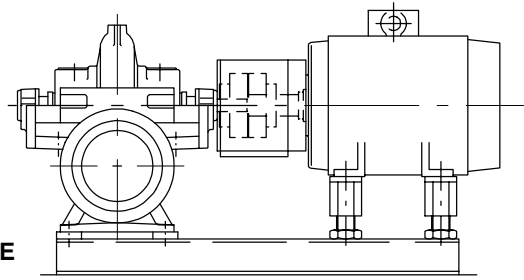

**Pump set with close-coupled motor (type IM B3)  
Baseplate, base frame, coupling guard and motor height adjustment**

**Vertical**

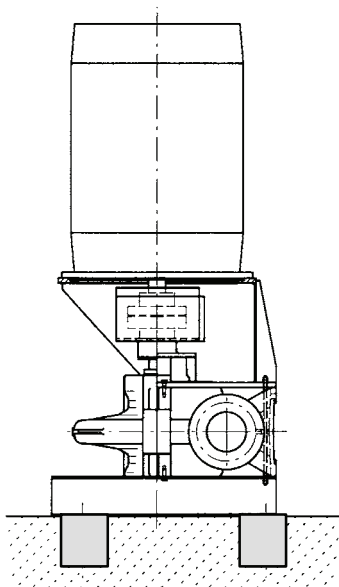

**Type of arrangement DB <sup>1)</sup>**

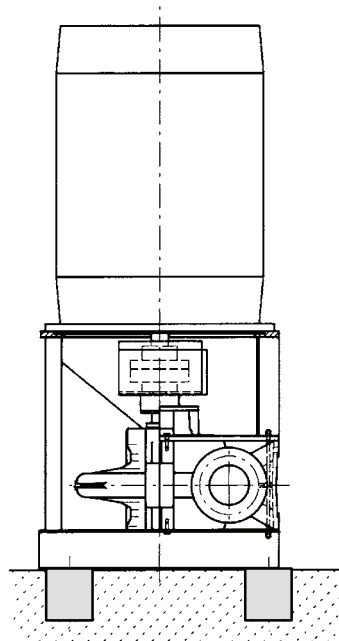

**Type of arrangement DK <sup>1)</sup>**

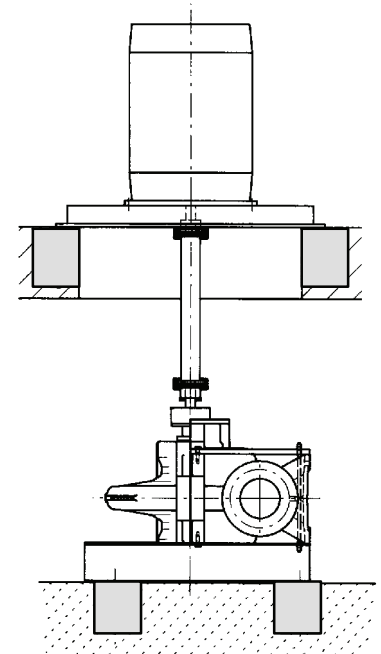

**Type of arrangement DJ**

Optionally with intermediate bearing

<sup>1)</sup> Depending on motor size, see arrangement drawings, pp. 34-49

**Direction of rotation / flow direction**

**Horizontal**

Direction of rotation  
**anticlockwise**,  
viewed from the drive  
end

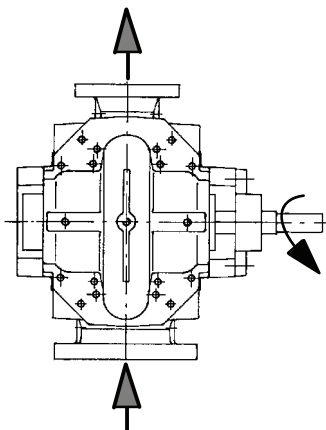

Direction of rotation  
**clockwise**, viewed  
from the drive end

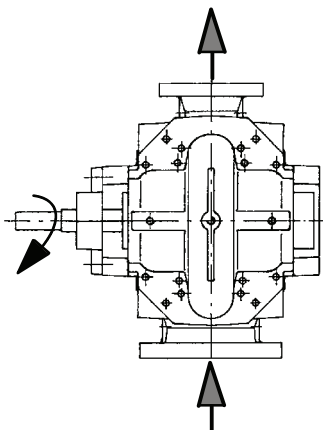

**Vertical**

Direction of rotation  
**anticlockwise**,  
viewed from the drive  
end

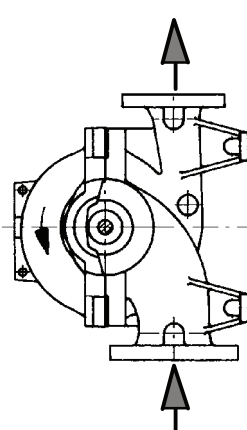

Direction of rotation  
**clockwise**, viewed  
from the drive end

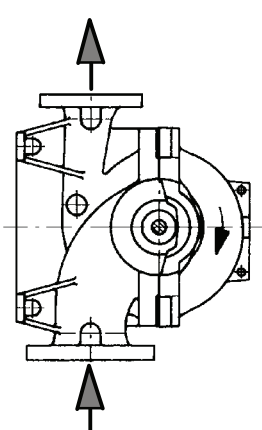

**Materials / Application limits**

Temperatures		Stuffing box / mechanical seal : max. 105 °C				
Liquid handled (Fields of application)		see separate recommendation for material combination (table of pumped media)				
Part no.	Part designation	Material combinations				
		GB	SB	SC	NC	C
102	Volute casing	JL 1040	JS 1030	JS 1030	GGG-NiCrNb202	1.4517 / 1.4593
211	Pump shaft	1.4021			1.4462	
234	Impeller	G-CuSn10		1.4517 / 1.4593		
350.1	Bearing housing	JL 1040				
360	Bearing cover	JL 1040				
441	Housing for shaft seal	JL 1040	JS 1030		GGG-NiCrNb202	1.4517
452	Gland	RST 37-2			1.4571	
455	Stuffing box insert	GZ-CuSn7ZnPb			1.4571	
457	Neck ring	GZ-CuSn7ZnPb			1.4581	
458	Lantern ring	GZ-CuSn7ZnPb			CrNi-steel	
502	Casing wear ring	GZ-CuSn7ZnPb			1.4470	
503	Impeller wear ring (optional)	GZ-CuSn7ZnPb		1.4470		
524	Shaft protecting sleeve	1.4138				
433	Mechanical seal	Si-SiC / Si-SiC (Q1 Q1 V G G to DIN 24960)				
901.1	Companion bolt	10.9			1.4462	
703	Sealing water or flush pipe	PTFE / steel galv. Zn		PTFE / 1.4571	PTFE / duplexsteel	

<sup>1)</sup> permitted for sizes, see table " Pressure limits and material combinations", below

JL 1040 → GG-25  
JS 1030 → GGG-40

**Pressure limits and material combinations**

Pump sizes	Max. permissible operating pressures in bar				
	Material combinations				
	GB	SB	SC	NC	C
80-210					
80-270					
80-370					
100-250					
100-310					
100-375					
125-230					
125-290	16			16	
125-365					
125-500					
150-290					
150-360		25	25		25
150-460					
150-605	24			24	
200-320					
200-420	16			16	
200-520					
200-670	24			24	
250-370 <sup>2)</sup>	10			10	
250-480	16			16	
250-600	24			24	
300-300 <sup>2)</sup>					
300-435 <sup>2)</sup>	10			10	
300-560	16			16	
300-700	24			24	
350-360 <sup>2)</sup>					
350-430 <sup>2)</sup>	10			10	
350-510 <sup>2)</sup>					

<sup>2)</sup> For material combinations GB and NC the maximum permissible operating pressure is dictated by the flange design according to ANSI B 16.1 Class 125 standard.

**N. B. :** - With a test pressure of  $p > 20$  bar, use a balanced mechanical seal (pressure test)  
- Although the operating pressure and the nominal pressure of the casing flange are not directly related, the nominal pressure of the flange to be used has to be one pressure stage higher than the guaranteed operating pressure.

**Recommended material combinations (table of pumped media)**

No.	Pumped medium	Description	GB	SB	SC	NC	C	First choice	Gland packing	Mech. seal	Remarks / additional recommendations
1	Petrol (gasoline) / kerosene		-	-	-	-	-	-	-	-	Omega pumps not suitable
2	Diesel fuel		-	-	-	-	-	-	-	-	
3	Liquefied gases		-	-	-	-	-	-	-	-	
4	Brackish water		-	-	-	0	+	C	+	+	
5	Sea water		-	-	-	+	+		+	+	
6	River water	containing up to 0.1 g/l of solids	+	+	+	+	+	GB	+	+	
7	Rainwater	prescreened mechanically	+	+	+	+	+		+	+	
8	Industrial water		+	+	+	+	+	GB	+	+	
9	Raw water	containing up to 0.1g/l of solids	+	+	+	+	+		+	+	only without NFPA-certification
10	Fire-extinguishing water		+	+	+	+	+		+	+	
11	Pure water		+	+	+	+	+		+	+	
12	Potable water		+	0	0	+	+	GB	+	+	including internal coat of paint approved for drinking water applications on GB-design
13	De-mineralised water		0	0	0	+	+	NC	+	+	
14	Cooling water		+	+	+	+	+	GB	+	+	
15	Condensate		-	0	+	+	+	SC	-	+	
16	Hot water		-	+	+	-	+	SB	-	+	
17	Heating water		-	+	+	-	+	SB	-	+	
18	Boiler feed water		-	-	+	-	+	SC	+	+	Observe temperature limit of 105 °C. Balanced mechanical seal > 16 bar
19	Cooling tower water		-	-	+	-	+		+	+	
20	Washing water		+	+	+	+	+	GB	+	+	
21	Industrial water	neutral (pH = 6...8)	+	+	+	+	+		+	+	
22	Industrial water	slightly acidic/basic (pH = 4...9)	-	-	-	+	+	NC/C	-	+	
23	Industrial water	highly acidic/basic (pH = 1...11)	-	-	-	-	+	C	-	+	
24	Oil emulsion	viscosity max. 20 mm <sup>2</sup> /s	+	+	+	+	+	GB	-	+	Mechanical seal flushed from an outside source (on request)
25	Water / sand mixture	max. solids content 0.1 g/l for continuous operation max. solids content 0.2 g/l for intermittent operation	0	0	+	0	+	SC	+	+	
26	Water, chemically neutral with regard to corrosion, charged with aromatic hydrocarbons	e.g. benzene, styrene	-	+	+	+	+	SB	-	+	On request (depending on the medium pumped, the concentration and the temperature)
27	Water, chemically neutral with regard to corrosion, charged with chlorinated hydrocarbons	e.g. trichloroethylene, ethylene dichloride	-	+	+	+	+	SB	-	+	
28	Scale-forming water		-	-	0	-	0	SC/C	+	+	On request (solids content and grain size to be indicated)

+ suitable

o suitable with reservations

- not suitable

Maximum working temperature 105 °C

Maximum solids content of the medium pumped 0.1 mg/l with continuous operation; 0.2 g/l with intermittent operation.

**Technical data**

all dimensions in mm

Pump sizes	Shaft units	Nominal diameter stuffing box / mechanical seal d	Stuffing box data		
			Diameter D	Length L	Number of packing rings per gland
80-210	40	50	70	60	3
80-270					
80-370					
100-250					
100-310					
100-375	50	60	85	72	
125-230					
125-290					
125-365					
125-500					
150-290	60	70	95	72	
150-360					
150-460					
150-605					
200-320					
200-420	70	80	112	93	
200-520					
200-670					
250-370					
250-480					
250-600	80	90	122	93	
300-300					
300-435					
300-560	90	110	150	120	
300-700					
350-360					
350-430	80	90	122	93	
350-510					
350-510	90	110	150	120	

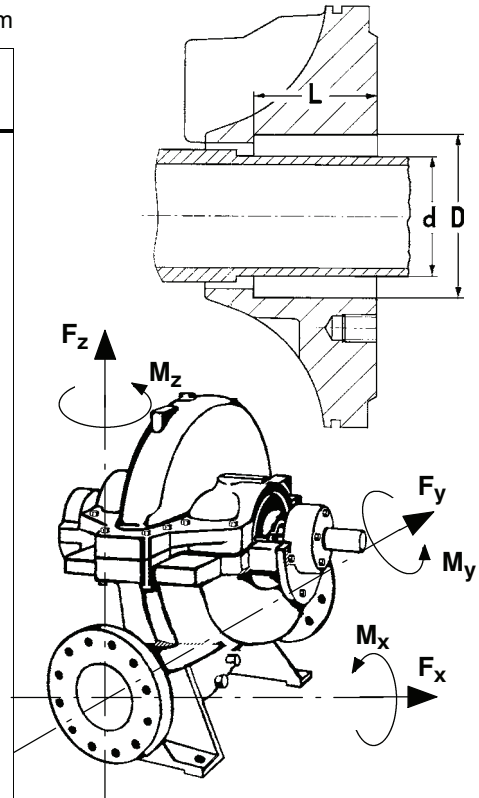

1) Values are valid for casing materials JL 1040 and GGG-NiCrNb 202.  
For casing material JS 1030 multiply value by 1.4, for 1.4517 multiply value by 1.9.

Pump sizes	Impeller dimensions in mm				Permissible nozzle forces $F_x, F_y, F_z$ <sup>1)</sup> N	Permissible nozzle moments $M_x, M_y, M_z$ <sup>1)</sup> Nm	Mass moments of inertia J (without coupling) kgm <sup>2</sup>	
	free passage +/- 10%			max. diameter			without water	with water
	A-Imp.	B-Imp.	C-Imp.	A-, B-, C-Imp.				
80-210	15	11	-	215	800	500	0.023	0.028
80-270	13	9	-	275			0.037	0.044
80-370	11	8	-	345			0.027	0.032
100-250	19	14	-	254	1000	700	0.048	0.058
100-310	15	11	-	325			0.092	0.110
100-375	13	10	-	408			0.229	0.275
125-230	23	17	-	245	1500	1000	0.161	0.193
125-290	19	12	-	301			0.125	0.150
125-365	14	10	-	392			0.261	0.313
125-500	14	10	-	482	2000	1500	0.688	0.825
150-290	27	20	14	289			0.169	0.288
150-360	22	15	-	355			0.199	0.338
150-460	17	12	-	462	3000	2000	0.456	0.775
150-605	16	11	-	569			1.074	1.825
200-320	30	22	17	338			0.442	0.575
200-420	26	18	-	415	4000	2750	0.588	0.725
200-520	20	14	-	540			1.288	1.675
200-670	18	12	-	665			3.654	4.750
250-370	39	27	20	390			0.721	1.225
250-480	30	20	-	478			0.956	1.625
250-600	23	16	-	622			2.206	3.750
300-300	39	27	-	323			0.571	0.800
300-435	45	32	30	450			1.785	2.500
300-560	35	23	-	553			2.411	3.375
300-700	26	18	-	719			6.346	8.250
350-360	39	27	-	373	5000	3000	1.116	1.563
350-430	57	40	-	430			2.232	3.125
350-510	52	36	35	518			3.393	4.750

## Speeds

For speeds in excess of the figures indicated in the sales documentation, please contact KSB indicating the required operating range.

**Speed control: Shaft sealing always by means of a mechanical seal.  
For speed control on Omega V, check-back with KSB.**

## Vibrations

Vibration values of the pump according to DIN ISO 1949, in the operating range from 0.5 up to  $1.2 \times Q_{Opt}$

- Omega :	Group G	$v_{eff} < 4.5 \text{ mm/s}$
- Omega V:	Group T	$v_{eff} < 7.0 \text{ mm/s}$

## Coating

### A ) Standard coating

Surface treatment:	SA 2½ to DIN 55928, Part 4
Corrosion control:	to AA 0080-06-01
Primer:	2-pack zinc-rich primer or 2-pack zinc phosphate

**Top coat : KSB standard**

2-pack epoxy resin, layer thickness approx. 0.10 mm, colour RAL 5002 (ultramarine blue)

### B ) Internal coating - approved for potable water (standard variant for GB-design)

Surface treatment:	SA 2½ to DIN 55928, Part 4
Corrosion control:	to AA 0080-06-01
Primer	2-pack zinc-rich primer or 2-pack zinc phosphate

**Top coat (inside):**

2-pack epoxy resin, layer thickness approx. 0.125 mm, colour RAL 9005 (black)

**Arrangement of sealing water and flush pipes**

**01** Sealing water pipe for gland packing



**02** Flush pipe for mechanical seal

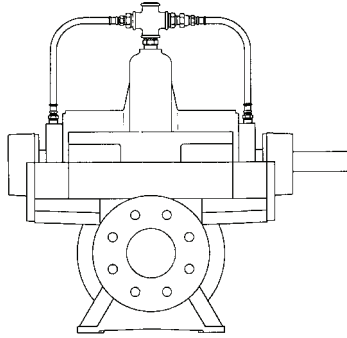

**03** Sealing water pipe for gland packing  
Flush pipe for Residur® bearing

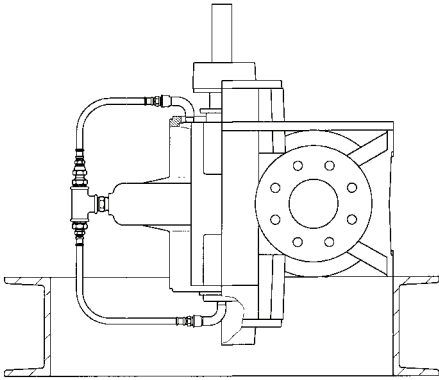

**04** Flush pipe for mechanical seal  
Flush pipe for Residur® bearing

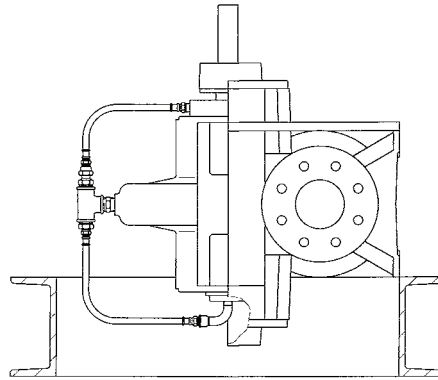

**Arrangement of venting connections and bearing temperature sensor** (vent valves are available as accessories)

**05** Vent valve

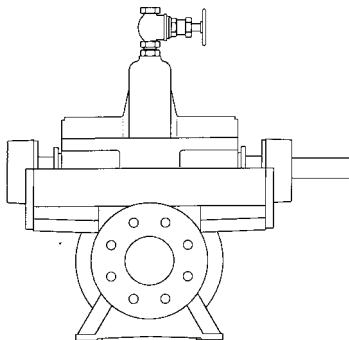

**06** Sealing water pipe for gland packing  
with vent valve

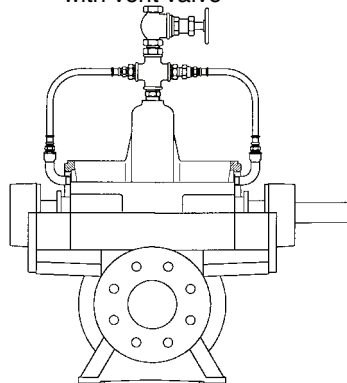

Bearing temperature  
sensor PT 100

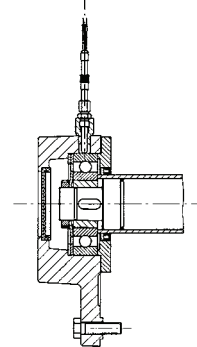

**07** Flush pipe for Residur®  
bearing and vent valve

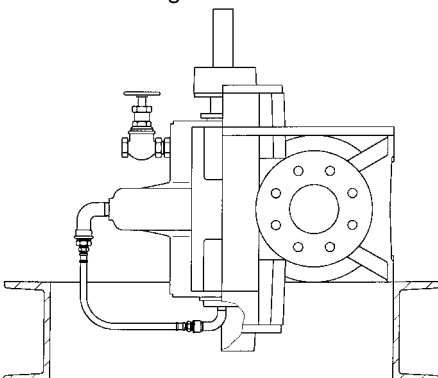

**08** Flush pipe for mechanical seal, Residur® bearing  
and vent valve

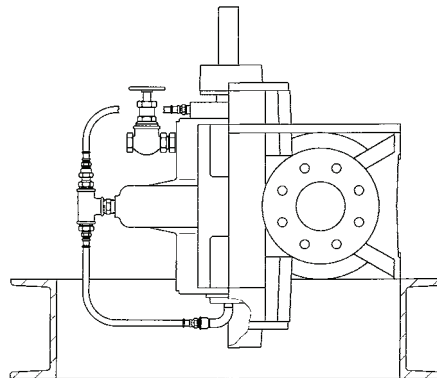

**General drawing**

Horizontal installation Omega 80-210 up to 350-51

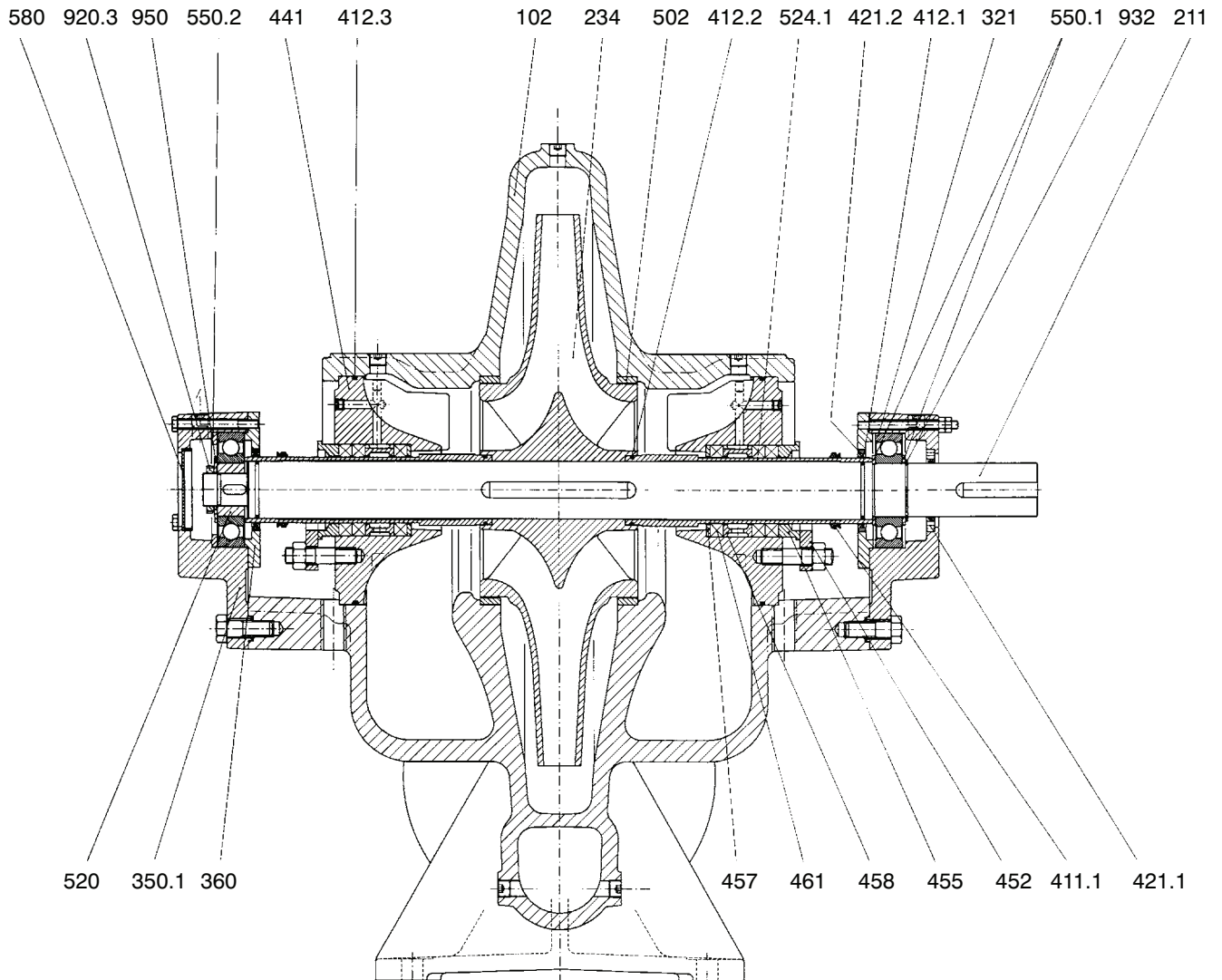

Part no.	Part designation	Part no.	Part designation	Part no.	Part designation
102	Volute casing	452	Gland	920	Nut
211	Pump shaft	461	Gland packing	932	Circlip
234	Impeller	455	Stuffing box insert	950	Spring
321	Deep groove ball bearing	457	Neck ring		
350. ...	Bearing housing	458	Lantern ring		
360	Bearing cover	502	Casing wear ring		
411. ...	V-Ring	520	Sleeve		
412. ...	O-Ring	524	Shaft protecting sleeve		
421	Radial shaft seal ring	550. ...	Washer		
441	Housing for shaft seal	580	Cap		

**General drawing**

Vertical installation DB , Omega V 80-210 up to 350-510

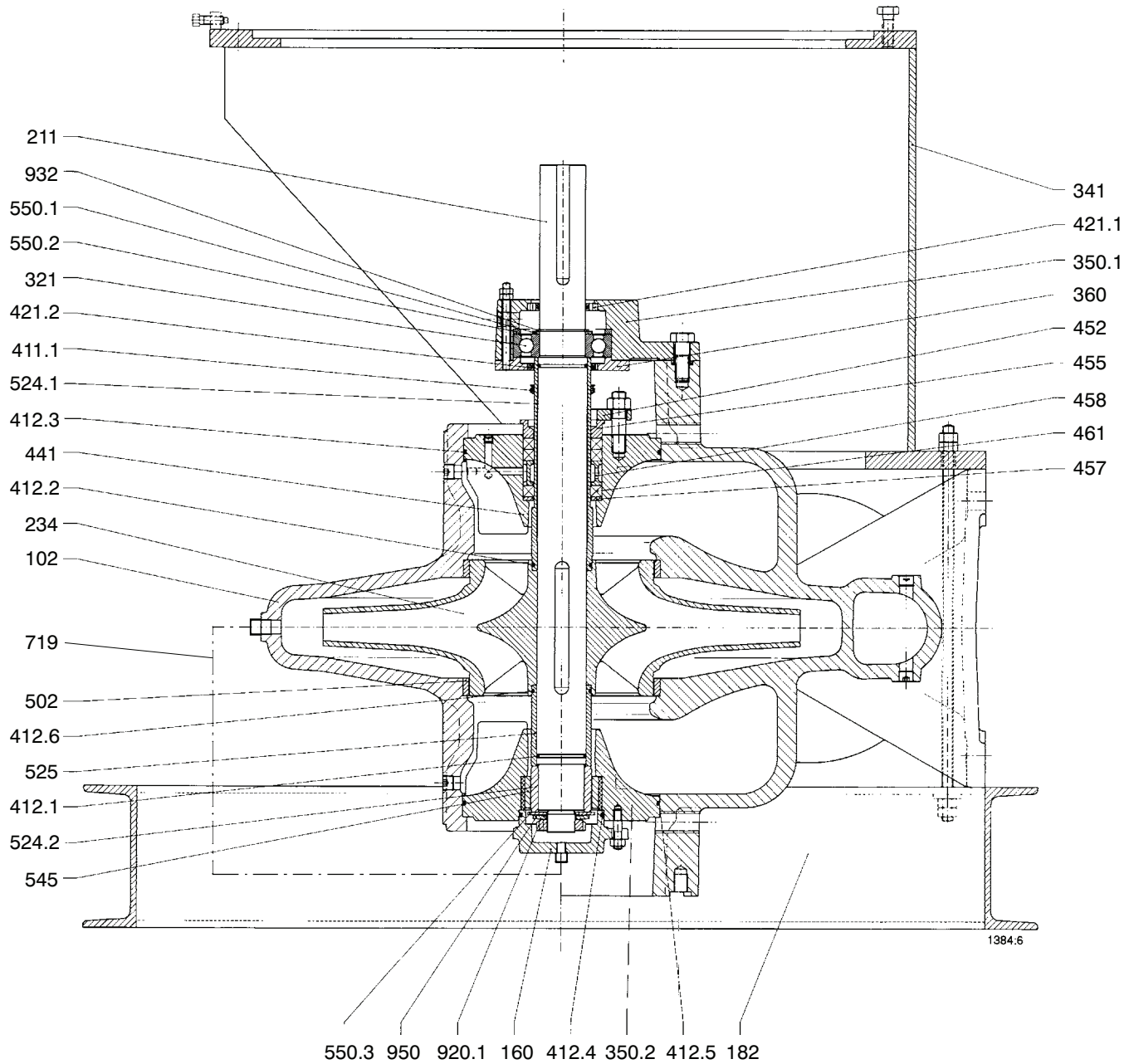

Part no.	Part designation	Part no	Part designation	Part no	Part designation
102	Volute casing	411. ...	V-Ring	502	Casing wear ring
160	Cover	412. ...	O-Ring	524	Shaft protecting sleeve
182	Foot	421. ...	Radial shaft seal ring	525	Spacer sleeve
211	Pump shaft	441	Housing for shaft seal	545	Bearing bush
234	Impeller	452	Gland	550. ...	Washer
321	Deep groove ball bearing	461	Gland packing	719	Flexible tube
341	Motor stool	455	Stuffing box insert	920	Nut
350. ...	Bearing housing	457	Neck ring	932	Circlip
360	Bearing cover	458	Lantern ring	950	Spring

**Mechanical seals, standard design**

Standard mechanical seal acc. to DIN 24960

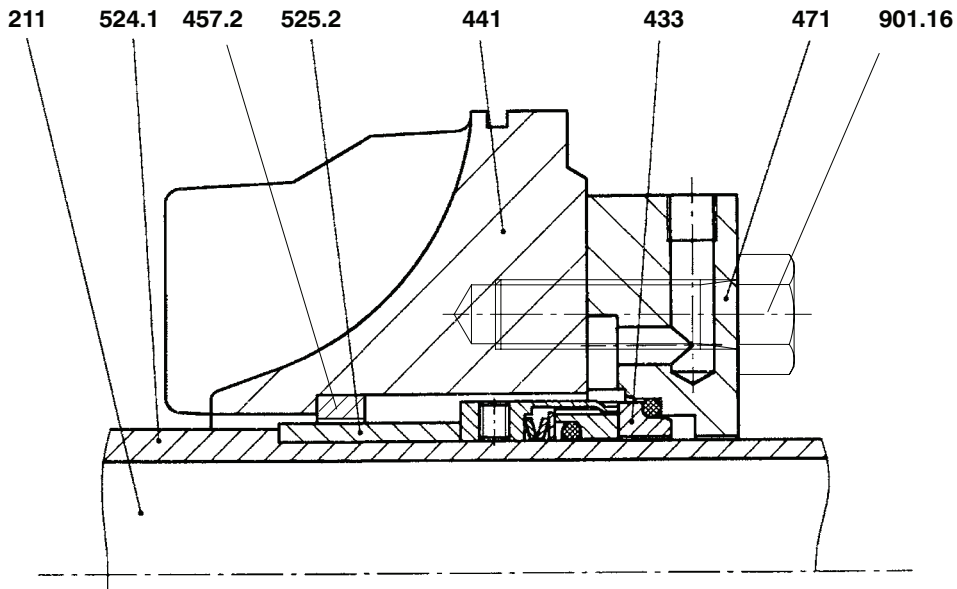

**Balanced mechanical seal (when operating pressure  $p > 16$  bar)**

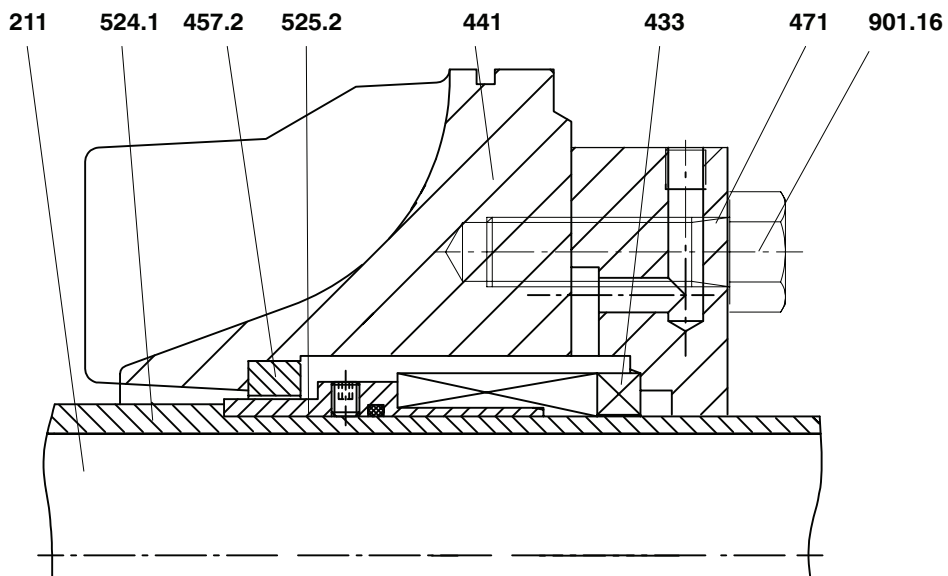

Part no	Part designation	Part no	Part designation
211	Pump shaft	471	Seal cover
433	Mechanical seal	524.1	Shaft protecting sleeve
441	Housing for shaft seal	525.2	Spacer sleeve
457.2	Neck ring	901.16	Hexagon head bolt

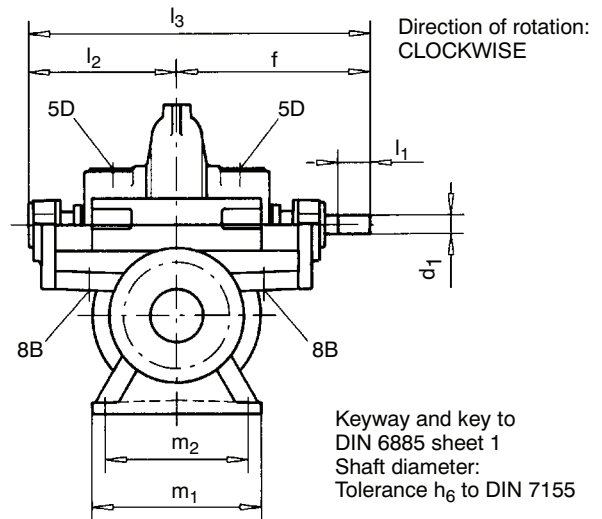
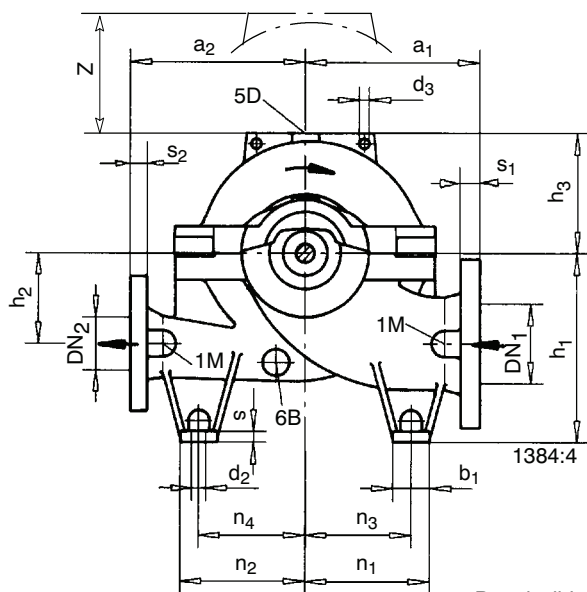
**Table of dimensions Omega 80 - 210 up to 150 - 605**

Keyway and key to  
DIN 6885 sheet 1  
Shaft diameter:  
Tolerance  $h_6$  to DIN 7155

Flanges:  
- Flat surface flanges  
- Flange thickness to ANSI  
- Connect pipes without stress

Permissible deviations for:  
- Centreline heights  
- Dimensions without indication  
of tolerances  
- Cast iron parts

DIN 747  
DIN 7168, medium  
DIN 1686 GTB 18

Connections:  
- 1M Pressure gauge G 1/2  
- 5D Vent G 1/2  
- 6B Drainage G 1/2  
- 8B Leakage liquid drain G 3/4

**Major external pump dimensions and weights**

all dimensions in mm

Pump size	Flange dimensions				Pump dimensions									
	DN <sub>1</sub>	DN <sub>2</sub>	s <sub>1</sub>	s <sub>2</sub>	a <sub>1</sub> <sup>2)</sup>	a <sub>2</sub> <sup>2)</sup>	d <sub>3</sub>	f	h <sub>1</sub>	h <sub>2</sub>	h <sub>3</sub>	l <sub>2</sub>	l <sub>3</sub>	z <sup>1)</sup>
80-210	125	80	34	29	300	300	19	415	315	140	168	300	715	340
80-270					330	330					190			380
80-370					330	330					225			450
100-250	150	100	37	32	330	330	19	415	355	170	195	300	715	390
100-310					370	370					225			450
100-375					370	370					260			520
125-230	200	125	41	35	370	370	19	515	400	200	210	366	881	420
125-290											230			460
125-365											260			520
125-500					305	610								
150-290					245	490								
150-360	200	150	41	37	400	400	19	515	400	200	265	366	881	530
150-460					450	450					305			610
150-605					600	500					590			500

Pump size	Foot dimensions									Shaft		Weights [kg]	
	b <sub>1</sub>	d <sub>2</sub>	m <sub>1</sub>	m <sub>2</sub>	n <sub>1</sub>	n <sub>2</sub>	n <sub>3</sub>	n <sub>4</sub>	s	d <sub>1</sub>	l <sub>1</sub>	Pump	Water content
80-210	70	17,5	320	270	205	205	170	170	20	35	80	185	10
80-270					195	15							
80-370					205	20							
100-250	70	17,5	320	270	235	235	200	200	20	35	80	210	20
100-310					225	25							
100-375					245	30							
125-230	70	17,5	390	340	260	260	225	225	20	45	100	250	35
125-290					275	40							
125-365					300	45							
125-500					315	315	280	280	335			55	
150-290					350	50							
150-360	70	17,5	390	340	260	260	225	225	20	45	100	360	60
150-460					315	315	280	280				440	75
150-605					480	430	385	385				350	380

<sup>1)</sup> z = the dimensions to be maintained around the casing cover for dismantling of the rotor

<sup>2)</sup> material combinations SB and SC: dimensions are 1% larger

**Standard flange design <sup>1)</sup>:**

Pump size	JL 1040 / GGG-NiCrNb 202 Nominal pressure acc. to:			JS 1030 / 1.4517 Nominal pressure acc. to:		
	DIN 2501 ISO 7005/2	BS 4504	ANSI B 16.1	DIN 2501 ISO 7005/2	BS 4504	ANSI B 16.1
80-210	PN 16	Table 16/11	Class 250	PN 25	Table 25/11	Class 250
80-270						
80-370						
100-250	PN 16	Table 16/11	Class 250	PN 25	Table 25/11	Class 250
100-310						
100-375						
125-230	PN 16	Table 16/11	Class 250	PN 25	Table 25/11	Class 250
125-290						
125-365						
125-500						
150-290	PN 16	Table 16/11	Class 250	PN 25	Table 25/11	Class 250
150-360						
150-460						
150-605						
	PN 25	Table 25/11				

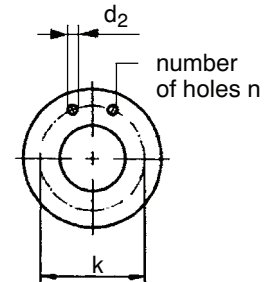
<sup>1)</sup> Other flange designs are available on request

**Flange dimensions - Drilling diagram**

all dimensions in mm

Standard		DN 80			DN 100			DN 125			DN 150			DN 200		
		d <sub>2</sub>	k	n	d <sub>2</sub>	k	n	d <sub>2</sub>	k	n	d <sub>2</sub>	k	n	d <sub>2</sub>	k	n
ISO 7005/2 DIN 2501	PN 16	19	160	8	19	180	8	19	210	8	23	240	8	23	295	12
ISO 7005/2 DIN 2501	PN 25	19	160	8	23	190	8	28	220	8	28	250	8	28	310	12
BS 4504	Table 16/11	19	160	8	19	180	8	19	210	8	23	240	8	23	295	12
BS 4504	Table 25/11	19	160	8	23	190	8	28	220	8	28	250	8	28	310	12
ANSI B 16.1	Class 250	23	168	8	23	200	8	23	235	8	23	270	12	28	330	12

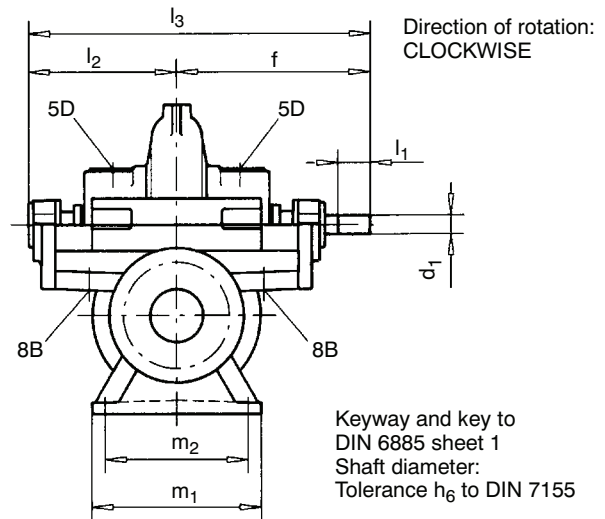
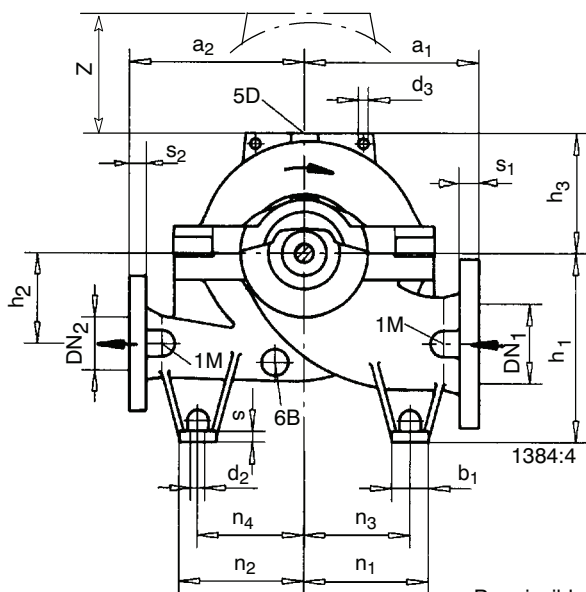
**Table of dimensions Omega 200 - 320 up to 350 - 510**

Flanges:  
 - Flat surface flanges  
 - Flange thickness to ANSI  
 - Connect pipes without stress

Permissible deviations for:  
 - Centreline heights  
 - Dimensions without indication of tolerances  
 - Cast iron parts

Connections:  
 - 1M Pressure gauge G 1/2  
 - 5D Vent G 1/2  
 - 6B Drainage G 1/2  
 - 8B Leakage liquid drain G 3/4

**Major external pump dimensions and weights**

all dimensions in mm

Pump size	Flange dimensions				Pump dimensions										
	DN <sub>1</sub>	DN <sub>2</sub>	s <sub>1</sub>	s <sub>2</sub>	a <sub>1</sub> <sup>3)</sup>	a <sub>2</sub> <sup>3)</sup>	d <sub>3</sub>	f	h <sub>1</sub>	h <sub>2</sub>	h <sub>3</sub>	l <sub>2</sub>	l <sub>3</sub>	z <sup>2)</sup>	
200-320	250	200	48	41	450	450	24,5	590	500	240	285	399	989	570	
200-420					500	500			310	620					
200-520					600	600			370	740					
200-670					650	550			430	860					
250-370	300	250	33 (51) <sup>1)</sup>	32 (48) <sup>1)</sup>	500	500	12,5	655	600	300	320	464	1119	640	
250-480			51	48	550	550		730	355	710					
250-600			650	630	350	415		830							
300-300	350	300	36 (54) <sup>1)</sup>	33	550	500	24,5	655	630	300	360	464	1119	720	
300-435	38 (57) <sup>1)</sup>		(51) <sup>1)</sup>	650	550	730		350	365	515	1245			730	
300-560	400		57	51	700	650		810	350	430	585			1395	860
300-700	750		750	400	480	960									
350-360	400	350	38 (57) <sup>1)</sup>	36 (54) <sup>1)</sup>	650	550	24,5	730	670	350	410	515	1245	820	
350-430	450		41 (60) <sup>1)</sup>		750	650		810	400	465	585			1395	930
350-510	400		38 (57) <sup>1)</sup>		700	700		810	750	400	420			840	

Pump size	Foot dimensions									Shaft		Weights [kg]	
	b <sub>1</sub>	d <sub>2</sub>	m <sub>1</sub>	m <sub>2</sub>	n <sub>1</sub>	n <sub>2</sub>	n <sub>3</sub>	n <sub>4</sub>	s	d <sub>1</sub>	l <sub>1</sub>	Pump	Water content
200-320	70	17,5	480	430	315	315	280	280	20	55	125	450	80
200-420				400	385	385	350	350	26	65	140	520	95
200-520		22		400	400	400						840	115
200-670				100	400	400	990	140					
250-370	100	22	480	400	400	400	350	350	26	65	140	665	125
250-480			600	520						830	145		
250-600		1215	180										
300-300		65	140	630						100			
300-435	100	22	600	520	400	400	350	350	26	75	160	905	190
300-560					525	525	475	475		85	180	1425	225
300-700		1690			275								
350-360		75			160	865	160						
350-430	100	22	600	520	400	400	350	350	26	85	180	1285	240
350-510					525	525	475	475				1395	290

<sup>1)</sup> For casing material GGG-NiCrNb 202, JS 1030, 1.4517

<sup>2)</sup> z = the dimensions to be maintained around the casing cover for dismantling of the rotor

<sup>3)</sup> material combinations SB and SC: dimensions are 1% larger

**Standard flange design <sup>1)</sup>:**

Pump size	JL 1040 / GGG-NiCrNb 202 Nominal pressure acc. to:			JS 1030 / 1.4517 Nominal pressure acc. to:		
	DIN 2501 ISO 7005/2	BS 4504	ANSI B 16.1	DIN 2501 ISO 7005/2	BS 4504	ANSI B 16.1
200-320	PN 16	Table 16/11	Class 250	PN 25	Table 25/11	Class 250
200-420						
200-520						
200-670	PN 25	Table 25/11				
250-370	PN 10	Table 10/11	Class 125	PN 25	Table 25/11	Class 250
250-480	PN 16	Table 16/11	Class 250			
250-600	PN 25	Table 25/11	Class 250			
300-300	PN 10	Table 10/11	Class 125	PN 25	Table 25/11	Class 250
300-435						
300-560						
300-700	PN 25	Table 25/11	Class 250			
350-360	PN 10	Table 10/11	Class 125	PN 25	Table 25/11	Class 250
350-430						
350-510						

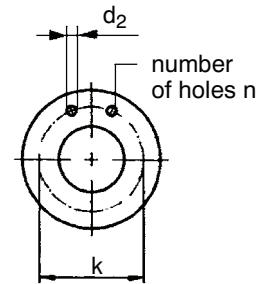

<sup>1)</sup> Other flange designs are available on request

**Flange dimensions - Drilling diagram**

all dimensions in mm

Standard		DN 200			DN 250			DN 300			DN 350			DN 400			DN 450		
		d <sub>2</sub>	k	n	d <sub>2</sub>	k	n	d <sub>2</sub>	k	n	d <sub>2</sub>	k	n	d <sub>2</sub>	k	n	d <sub>2</sub>	k	n
ISO 7005/2 DIN 2501	PN 10	23	295	8	23	350	12	23	400	12	23	460	16	28	515	16	28	565	20
ISO 7005/2 DIN 2501	PN 16	23	295	12	28	355	12	28	410	12	28	470	16	31	525	16	31	585	20
ISO 7005/2 DIN 2501	PN 25	28	310	12	31	370	12	31	430	16	34	490	16	37	550	16	37	600	20
BS 4504	Table 10/11	23	295	8	23	350	12	23	400	12	23	460	16	28	515	16	28	565	20
BS 4504	Table 16/11	23	295	12	28	355	12	28	410	12	28	470	16	31	525	16	31	585	20
BS 4504	Table 25/11	28	310	12	31	370	12	31	430	16	34	490	16	37	550	16	37	600	20
ANSI B 16.1	Class 125	23	299	8	28	362	12	28	432	12	28	476	12	28	540	16	31	578	16
ANSI B 16.1	Class 250	28	330	12	28	387	16	31	451	16	31	514	20	34	572	20	34	629	24

**Table of dimensions Omega V 80 - 210 up to 150 - 605**
**Flanges:**

- Flat surface flanges
- Flange thickness to ANSI
- Connect pipes without stress

**Permissible deviations for:**

- Centreline heights DIN 747
- Dimensions without indication of tolerances DIN 7168, medium
- Cast iron parts DIN 1686 GTB 18

**Connections:**

- 1M Pressure gauge G 1/2
- 5D Vent G 1/2
- 6B Drainage G 1/2
- 8B Leakage liquid drain G 3/4

**Keyway and key to**

DIN 6885 sheet 1

**Shaft diameter:**

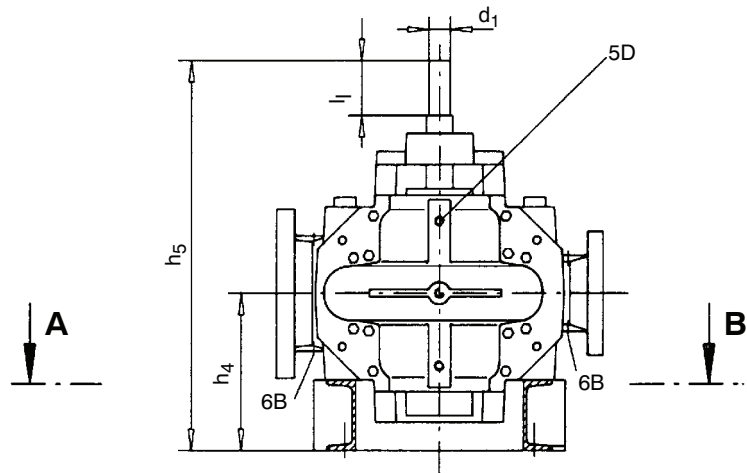
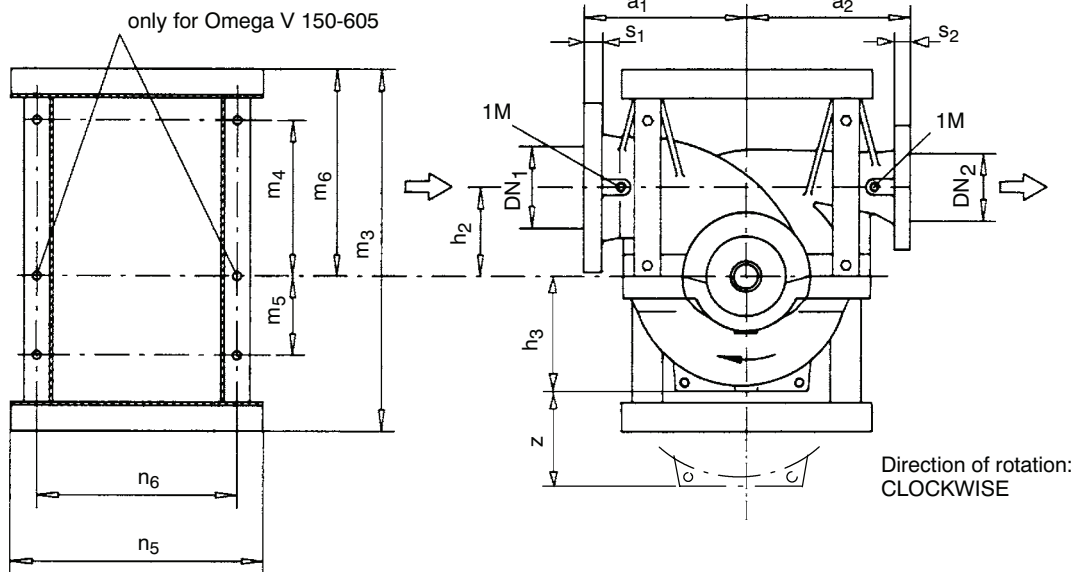
 Tolerance  $h_6$  to DIN 7155

**Section A - B**

**Major external pump dimensions**

all dimensions in mm

Pump size	Flange dimensions				Pump dimensions						
	DN <sub>1</sub>	DN <sub>2</sub>	s <sub>1</sub>	s <sub>2</sub>	a <sub>1</sub> <sup>2)</sup>	a <sub>2</sub> <sup>2)</sup>	h <sub>2</sub>	h <sub>3</sub>	h <sub>4</sub>	h <sub>5</sub>	z <sup>1)</sup>
80-210	125	80	34	29	300	300	140	168	300	715	340
80-270					190	380					
80-370					225	450					
100-250	150	100	37	32	330	330	170	195	300	715	390
100-310					225	450					
100-375					260	520					
125-230	200	125	41	35	370	370	200	210	355	870	420
125-290					230	460					
125-365					260	520					
125-500					305	610					
150-290	200	150	41	37	400	400	200	245	355	870	490
150-360					265	530					
150-460					305	610					
150-605					600	500		300			370

1) z = the dimensions to be maintained around the casing cover for dismantling of the rotor

2) material combinations SB and SC: dimensions are 1% larger

**Major external pump dimensions and weights** all dimensions in mm

Pump size	Foot dimensions						Shaft		Weights [kg]	
	m <sub>3</sub>	m <sub>4</sub>	m <sub>5</sub>	m <sub>6</sub>	n <sub>5</sub>	n <sub>6</sub>	d <sub>1</sub>	l <sub>1</sub>	Pump	Water content
80-210	640	275	100	380	450	340	35	80	185	10
80-270									195	15
80-370									205	20
100-250	695	315	115	420	500	400	35	80	210	20
100-310									225	25
100-375									245	30
125-230	855	360	210	475	600	450	45	100	250	35
125-290									275	40
125-365					300	45				
125-500					335	55				
150-290	855	360	210	475	600	450	45	100	350	50
150-360									360	60
150-460					440	75				
150-605	1060	460	315	575	900	700	55	125	650	90

**Standard flange design <sup>1)</sup>:**

Pump size	JL 1040 / GGG-NiCrNb 202 Nominal pressure acc. to:			JS 1030 / 1.4517 Nominal pressure acc. to:		
	DIN 2501 ISO 7005/2	BS 4504	ANSI B 16.1	DIN 2501 ISO 7005/2	BS 4504	ANSI B 16.1
80-210	PN 16	Table 16/11	Class 250	PN 25	Table 25/11	Class 250
80-270						
80-370						
100-250	PN 16	Table 16/11	Class 250	PN 25	Table 25/11	Class 250
100-310						
100-375						
125-230	PN 16	Table 16/11	Class 250	PN 25	Table 25/11	Class 250
125-290						
125-365						
125-500						
150-290	PN 16	Table 16/11	Class 250	PN 25	Table 25/11	Class 250
150-360						
150-460						
150-605	PN 25	Table 25/11				

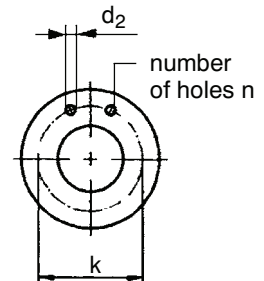
<sup>1)</sup> Other flange designs are available on request

**Flange dimensions - Drilling diagram**

all dimensions in mm

Standard		DN 80			DN 100			DN 125			DN 150			DN 200		
		d <sub>2</sub>	k	n	d <sub>2</sub>	k	n	d <sub>2</sub>	k	n	d <sub>2</sub>	k	n	d <sub>2</sub>	k	n
ISO 7005/2 DIN 2501	PN 16	19	160	8	19	180	8	19	210	8	23	240	8	23	295	12
ISO 7005/2 DIN 2501	PN 25	19	160	8	23	190	8	28	220	8	28	250	8	28	310	12
BS 4504	Table 16/11	19	160	8	19	180	8	19	210	8	23	240	8	23	295	12
BS 4504	Table 25/11	19	160	8	23	190	8	28	220	8	28	250	8	28	310	12
ANSI B 16.1	Class 250	23	168	8	23	200	8	23	235	8	23	270	12	28	330	12

**Table of dimensions Omega V 200 - 320 up to 350 - 510**
**Flanges:**

- Flat surface flanges
- Flange thickness to ANSI
- Connect pipes without stress

**Permissible deviations for:**

- Centreline heights DIN 747
- Dimensions without indication of tolerances DIN 7168, medium
- Cast iron parts DIN 1686 GTB 18

**Connections:**

- 1M Pressure gauge G 1/2
- 5D Vent G 1/2
- 6B Drainage G 1/2
- 8B Leakage liquid drain G 3/4

**Keyway and key to**

DIN 6885 sheet 1

**Shaft diameter:**

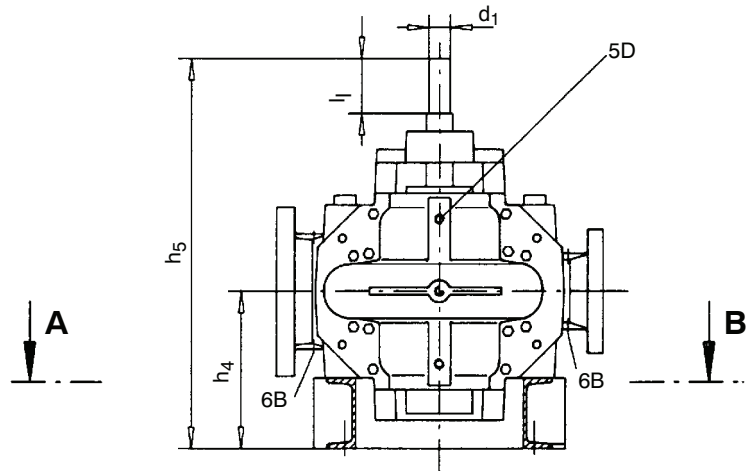
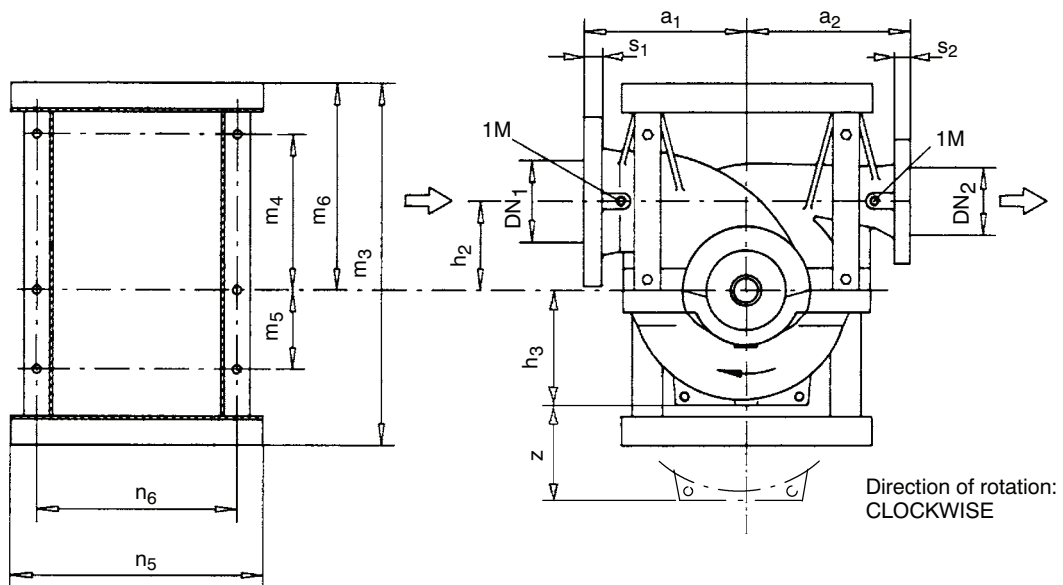
 Tolerance  $h_6$  to DIN 7155

**Section A - B**

**Major external pump dimensions**

all dimensions in mm

Pump size	Flange dimensions				Pump dimensions									
	DN <sub>1</sub>	DN <sub>2</sub>	s <sub>1</sub>	s <sub>2</sub>	a <sub>1</sub> <sup>3)</sup>	a <sub>2</sub> <sup>3)</sup>	h <sub>2</sub>	h <sub>3</sub>	h <sub>4</sub>	h <sub>5</sub>	z <sup>2)</sup>			
200-320	250	200	48	41	450	450	240	285	400	990	570			
200-420					500	500		310						
200-520					600	550		300				370	440	740
200-670					650	550		350				430	1095	860
250-370	300	250	33 (51) <sup>1)</sup>	32 (48) <sup>1)</sup>	500	500	300	320	440	1095	640			
250-480			51	48	550	550		355				710		
250-600			650	415	500	1230		830						
300-300	350	300	36 (54) <sup>1)</sup>	33	550	500	300	360	440	1095	720			
300-435	38 (57) <sup>1)</sup>		(51) <sup>1)</sup>	650	550	350	365	500	1230	730				
300-560	400		57	51	700	650	350	430	570	1380	860			
300-700					750		400	480			960			
350-360	400	350	38 (57) <sup>1)</sup>	36 (54) <sup>1)</sup>	650	550	350	410	500	1230	820			
350-430	450		41 (60) <sup>1)</sup>		750	550	350	465	500	1230	930			
350-510	400		38 (57) <sup>1)</sup>		36 (54) <sup>1)</sup>	700	650	400	420	570	1380	840		
						700		420	570	1380	840			

<sup>1)</sup> For casing material GGG-NiCrNb 202, JS 1030, 1.4517

<sup>2)</sup> z = the dimensions to be maintained around the casing cover for dismantling of the rotor

<sup>3)</sup> material combinations SB and SC: dimensions are 1% larger

**Major external pump dimensions and weights** all dimensions in mm

Pump size	Foot dimensions						Shaft		Weights [kg]	
	m <sub>3</sub>	m <sub>4</sub>	m <sub>5</sub>	m <sub>6</sub>	n <sub>5</sub>	n <sub>6</sub>	d <sub>1</sub>	l <sub>1</sub>	Pump	Water content
200-320	1060	460	315	575	700	560	55	125	450	80
200-420				635	900	700	65	140	520	95
200-520				685					840	115
200-670				1180	560	685	900	700	65	140
250-370	1180	560	315	685	900	700	65	140	665	125
250-480									715	830
250-600				1210	590	715	900	700	75	160
300-300	1210	590	315	715	900	700	65	160	630	100
300-435	1250	630		755			75	160	905	190
300-560	1375	670	400	795	1200	950	85	180	1425	225
300-700	1415	710		835					1690	275
350-360	1250	630	315	755	900	700	75	160	865	160
350-430	1415	710	400	835	1200	950	85	180	1285	240
350-510									1395	290

**Standard flange design <sup>1)</sup>:**

Pump size	JL 1040 / GGG-NiCrNb 202 Nominal pressure acc. to:			JS 1030 / 1.4517 Nominal pressure acc. to:		
	DIN 2501 ISO 7005/2	BS 4504	ANSI B 16.1	DIN 2501 ISO 7005/2	BS 4504	ANSI B 16.1
200-320	PN 16	Table 16/11	Class 250	PN 25	Table 25/11	Class 250
200-420						
200-520						
200-670	PN 25	Table 25/11	Class 250	PN 25	Table 25/11	Class 250
250-370	PN 10	Table 10/11				
250-480	PN 16	Table 16/11				
250-600	PN 25	Table 25/11	Class 250	PN 25	Table 25/11	Class 250
300-300	PN 10	Table 10/11				
300-435						
300-560	PN 16	Table 16/11	Class 250	PN 25	Table 25/11	Class 250
300-700	PN 25	Table 25/11				
350-360	PN 10	Table 10/11	Class 125	PN 25	Table 25/11	Class 250
350-430						
350-510						

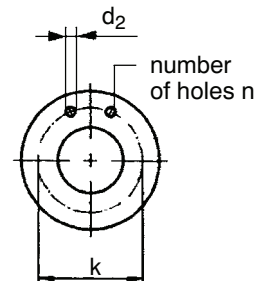
<sup>1)</sup> Other flange designs are available on request

**Flange dimensions - Drilling diagram**

all dimensions in mm

Standard		DN 200			DN 250			DN 300			DN 350			DN 400			DN 450		
		d <sub>2</sub>	k	n	d <sub>2</sub>	k	n	d <sub>2</sub>	k	n	d <sub>2</sub>	k	n	d <sub>2</sub>	k	n	d <sub>2</sub>	k	n
ISO 7005/2 DIN 2501	PN 10	23	295	8	23	350	12	23	400	12	23	460	16	28	515	16	28	565	20
ISO 7005/2 DIN 2501	PN 16	23	295	12	28	355	12	28	410	12	28	470	16	31	525	16	31	585	20
ISO 7005/2 DIN 2501	PN 25	28	310	12	31	370	12	31	430	16	34	490	16	37	550	16			
BS 4504	Table 10/11	23	295	8	23	350	12	23	400	12	23	460	16	28	515	16	28	565	20
BS 4504	Table 16/11	23	295	12	28	355	12	28	410	12	28	470	16	31	525	16	31	585	20
BS 4504	Table 25/11	28	310	12	31	370	12	31	430	16	34	490	16	37	550	16			
ANSI B 16.1	Class 125	23	299	8	28	362	12	28	432	12	28	476	12	28	540	16	31	578	16
ANSI B 16.1	Class 250	28	330	12	28	387	16	31	451	16	31	514	20	34	572	20	34	629	24

## General arrangement drawing Omega 80 - 210 up to 100 - 375

### Type of arrangement 3E

Direction of rotation: CLOCKWISE

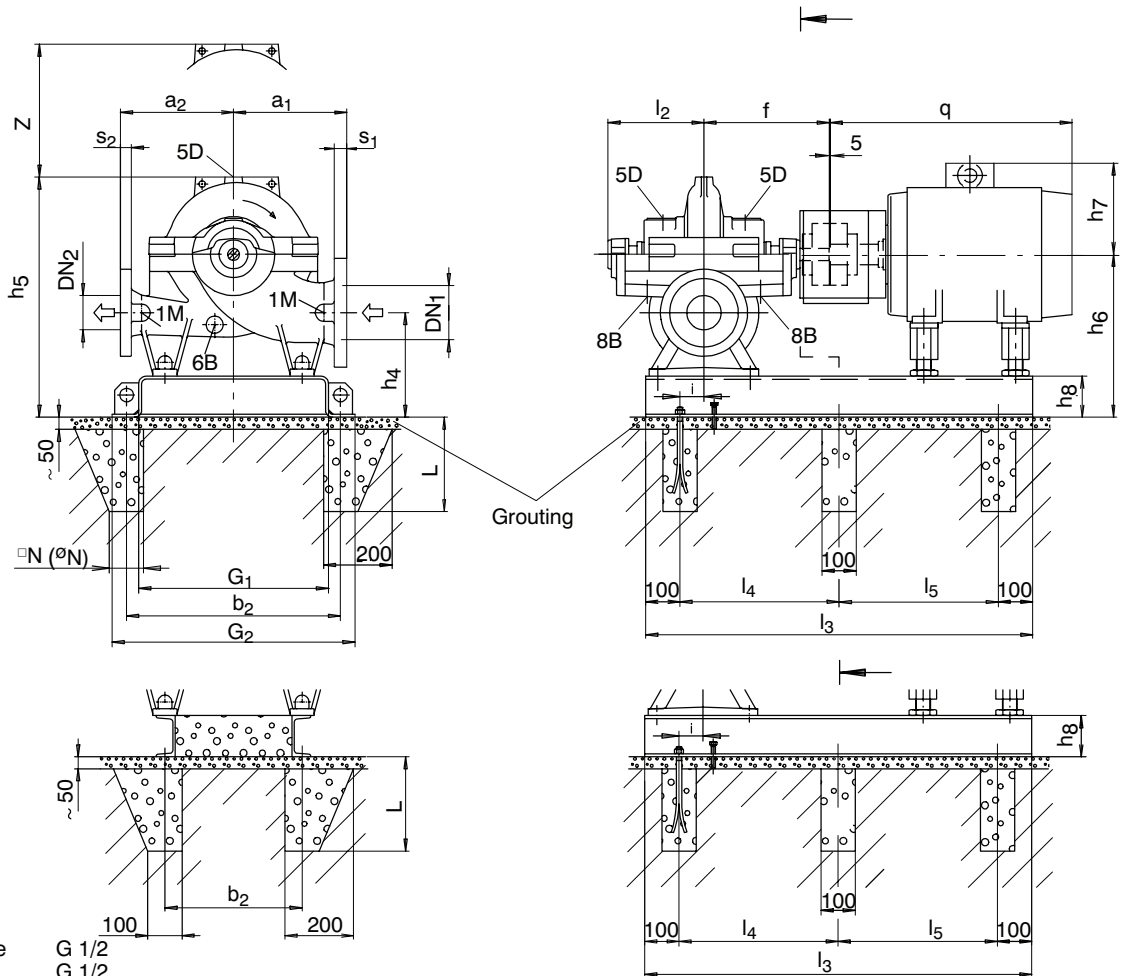

**Connections:**

- 1M Pressure gauge G 1/2
- 5D Vent G 1/2
- 6B Drainage G 1/2
- 8B Leakage liquid drain G 3/4

Grout baseplate / base frame with non-shrinking cement.  
Position of the terminal box, see "Motor dimension sheet".

The motor-dependent dimensions refer to KSB standard motors (see table "Motor dimensions and weights").

### Major external pump dimensions and weights

all dimensions in mm

Pump size	motor-dependent	Flange dimensions						Pump dimensions							Weight [kg]		
		DN <sub>1</sub>	DN <sub>2</sub>	s <sub>1</sub>	s <sub>2</sub>	a <sub>1</sub> <sup>2)</sup>	a <sub>2</sub> <sup>2)</sup>	f	h <sub>4</sub>	h <sub>5</sub> max.	h <sub>6</sub>	i	l <sub>2</sub>	z <sup>1)</sup>	Pump	Water content	
80-210	-	125	80	34	29	300	300	415	295	660	435	70	300	340	185	10	
80-270	up to 280 M					300	300		320					460			380
	up 315 S					300	300		295					435			450
80-370	-	150	100	37	32	330	330	415	305	760	475	70	300	450	205	20	
100-250	up to 280 M					330	330		330					500			390
	up 315 S					330	330		305					475			450
100-310	up to 280 M	150	100	37	32	330	330	415	330	760	475	70	300	450	225	25	
up 315 S	330													500			450
100-375	-	150	100	37	32	370	370	415	305	760	475	70	300	520	245	30	
														330			500

<sup>1)</sup> z = the dimensions to be maintained around the casing cover for dismantling of the rotor

<sup>2)</sup> material combinations SB and SC: dimensions are 1% larger

### Baseplate / base frame and foundation dimensions

all dimensions in mm

Baseplate size	Baseplate and foundation dimensions								Foundation bolts			Dowels		
	b <sub>2</sub>	G <sub>1</sub>	G <sub>2</sub>	l <sub>3</sub>	l <sub>4</sub>	l <sub>5</sub>	h <sub>8</sub>	Weight [kg]	Size	□N	L	Size	∅N	L
No Drawing no.														
1 0W 384 167-00	530	475	590	1190	495	495	120	74	M 16x250	100	250	M 12/25	18	110
2 0W 384 169-00	640	580	700	1400	600	600	120	97						
3 <sup>3)</sup> 0W 384 170-00	670	610	720	1630	715	715	145	105						

<sup>3)</sup> Base frame

**Standard flange design <sup>1)</sup>:**

Pump size	JL 1040 / GGG-NiCrNb 202 Nominal pressure acc. to:			JS 1030 / 1.4517 Nominal pressure acc. to:		
	DIN 2501 ISO 7005/2	BS 4504	ANSI B 16.1	DIN 2501 ISO 7005/2	BS 4504	ANSI B 16.1
80-210	PN 16	Table 16/11	Class 250	PN 25	Table 25/11	Class 250
80-270						
80-370						
100-250						
100-310						
100-375						

<sup>1)</sup> Other flange designs are available on request

**Flange dimensions - Drilling diagram**

all dimensions in mm

Standard	Suction flange				Discharge flange			
	DN	d <sub>2</sub>	k	n	DN	d <sub>2</sub>	k	n
Pump size 80-210 up to 80-370	125				80			
ISO 7005/2 DIN 2501 BS 4504	PN 16 Table 16/11	19 (M16)	210	8	19 (M16)	160	8	
ISO 7005/2 DIN 2501 BS 4504	PN 25 Table 25/11	28 (M24)	220					
ANSI B 16.1	Class 250	23 (M20)	235					
Pump size 100-250 up to 100-375	150				100			
ISO 7005/2 DIN 2501 BS 4504	PN 16 Table 16/11	23 (M20)	240	8	19 (M16)	180	8	
ISO 7005/2 DIN 2501 BS 4504	PN 25 Table 25/11	28 (M24)	250					
ANSI B 16.1	Class 250	23 (M20)	270					

Mating flange  
All flanges designed as plate flanges

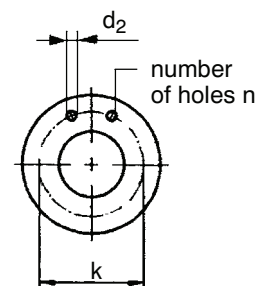
**Baseplate / motor combination**

Pump size	Motor size																			
	100L	112M	132S	132M	160M	160L	180M	180L	200L	225S	225M	250M	280S	280M	315S	315M	315L	315		
Number of poles	4	4	4	4	2	4	2	4	2	4	4	2	4	2	4	2	2	2	2	
80-210	1	1	1	1	1	1	1	1		1			2	2						
80-270	1	1	1	1	1	1	1	1		1			2	2	3					
80-370			1	1	1	1	1	1	1											
100-250	1	1	1	1	1	1	1	1		1			2	2	3	3				
100-310			1	1	1	1	1	1	1	1			2	2	3	3	3	3		
100-375					1	1	1	1	1	1	2		2	2						

- N.B.:
- The numbers listed in the table indicate the relevant baseplate numbers.
  - The baseplate numbers shown in the boxes also serve to select the correct motor size for the listed pump size.
  - Units comprising a motor size 315 and larger are completely assembled for verification and adjustment of the individual components. Before shipment, the units are dismantled again and the components packed / shipped separately.

### General arrangement drawing Omega 125 - 230 up to 150 - 360

Type of arrangement 3E

Direction of rotation: CLOCKWISE

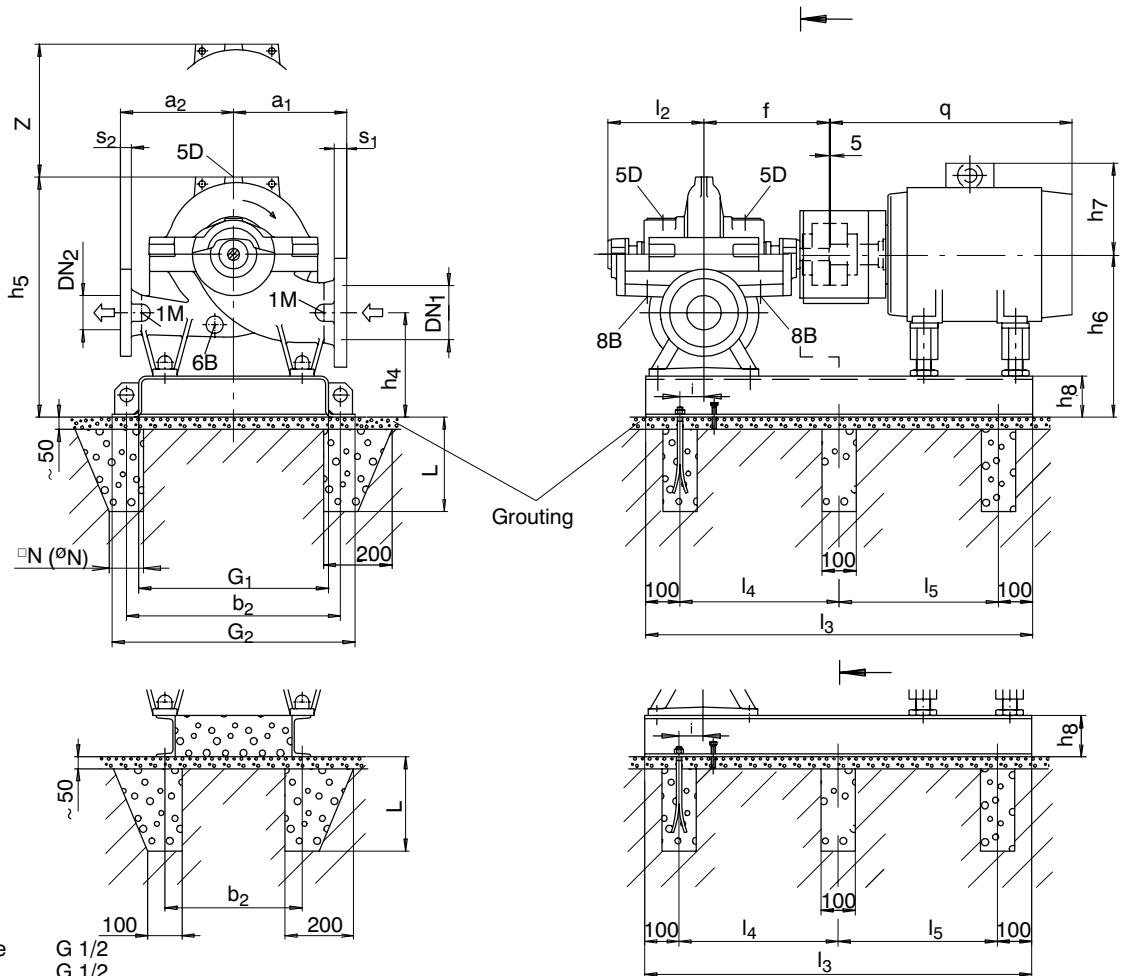

- Connections:
- 1M Pressure gauge G 1/2
  - 5D Vent G 1/2
  - 6B Drainage G 1/2
  - 8B Leakage liquid drain G 3/4

Grout baseplate / base frame with non-shrinking cement.  
Position of the terminal box, see "Motor dimension sheet".

The motor-dependent dimensions refer to KSB standard motors (see table "Motor dimensions and weights").

#### Major external pump dimensions and weights

all dimensions in mm

Pump size	motor-dependent	Flange dimensions						Pump dimensions					Weight [kg]							
		DN <sub>1</sub>	DN <sub>2</sub>	s <sub>1</sub>	s <sub>2</sub>	a <sub>1</sub> <sup>2)</sup>	a <sub>2</sub> <sup>2)</sup>	f	h <sub>4</sub>	h <sub>5</sub> max.	h <sub>6</sub>	i	l <sub>2</sub>	z <sup>1)</sup>	Pump	Water content				
125-230	up to 280 M up 315 S	200	125	41	35	370	370	515	320	825	520	120	366	420	250	35				
125-290	up to 280 M up 315 S								345		545						460	275	40	
									320		520									
125-365	-					345	545		610		335				55					
125-500	up to 280 M up 315 S					450	450									320	520	490	347	50
						320	520													
150-290	-	200	150	41	37	400	400	320	1050	520	530	359	60							
150-360	-																			

<sup>1)</sup> z = the dimensions to be maintained around the casing cover for dismantling of the rotor

<sup>2)</sup> material combinations SB and SC: dimensions are 1% larger

#### Baseplate / base frame and foundation dimensions

all dimensions in mm

Baseplate size	Baseplate and foundation dimensions								Foundation bolts			Dowels			
	No Drawing no.	b <sub>2</sub>	G <sub>1</sub>	G <sub>2</sub>	l <sub>3</sub>	l <sub>4</sub>	l <sub>5</sub>	h <sub>8</sub>	Weight [kg]	Size	□N	L	Size	∅N	L
4	0W 384 171-00	695	635	750	1330	565	565	120	92	M 16x250	100	250	M 12/25	18	110
5	0W 384 172-00	695	635	750	1540	670	670	120	106						
6 <sup>3)</sup>	0W 384 173-00	560	500	610	1820	810	810	145	110						

<sup>3)</sup> Base frame

**Standard flange design <sup>1)</sup> :**

Pump size	JL 1040 / GGG-NiCrNb 202 Nominal pressure acc. to:			JS 1030 / 1.4517 Nominal pressure acc. to:		
	DIN 2501 ISO 7005/2	BS 4504	ANSI B 16.1	DIN 2501 ISO 7005/2	BS 4504	ANSI B 16.1
125-230	PN 16	Table 16/11	Class 250	PN 25	Table 25/11	Class 250
125-290						
125-365						
125-500						
150-290						
150-360						

<sup>1)</sup> Other flange designs are available on request

**Flange dimensions - Drilling diagram**

all dimensions in mm

Standard	Suction flange				Discharge flange			
	DN	d <sub>2</sub>	k	n	DN	d <sub>2</sub>	k	n
Pump size 125-230 up to 125-500	200				125			
ISO 7005/2 DIN 2501 BS 4504	PN 16 Table 16/11	23 (M20)	295	12		19 (M16)	210	8
ISO 7005/2 DIN 2501 BS 4504	PN 25 Table 25/11	28 (M24)	310			28 (M24)	220	
ANSI B 16.1	Class 250	28 (M24)	330			23 (M20)	235	
Pump size 150-290 up to 150-360	200				150			
ISO 7005/2 DIN 2501 BS 4504	PN 16 Table 16/11	23 (M20)	295	12		23	240	8
ISO 7005/2 DIN 2501 BS 4504	PN 25 Table 25/11	28 (M24)	310			28	250	
ANSI B 16.1	Class 250	28 (M24)	330			23	270	

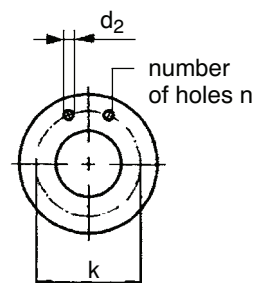
 Mating flange  
 All flanges designed as plate flanges

**Baseplate / motor combination**

Pump size	Motor size															
	132S	132M	160M	160L	180M	180L	200L	225S	225M	250M	280S	280M	315S	315M	315L	315
Number of poles	4	4	4	4	4	4	2	4	4	2	4	2	4	2	4	2
125-230	4	4	4	4	4	4	4		5	5	5	5	6	6		
125-290		4	4	4	4	4	4	5	5	5	5	5	6	6	6	6
125-365				4	4	4	4	5	5	5	5	5				
125-500							4	5	5	5	5	5	6	6		
150-290				4	4	4	4	5	5							
150-360				4	4	4	4	5	5	5	5	5				

- N.B.:
- The numbers listed in the table indicate the relevant baseplate numbers.
  - The baseplate numbers shown in the boxes also serve to select the correct motor size for the listed pump size.
  - Units comprising a motor size 315 and larger are completely assembled for verification and adjustment of the individual components. Before shipment, the units are dismantled again and the components packed / shipped separately.

### General arrangement drawing Omega 150 - 460 up to 250 - 370 and Omega 300 - 300

Type of arrangement 3E

Direction of rotation: CLOCKWISE

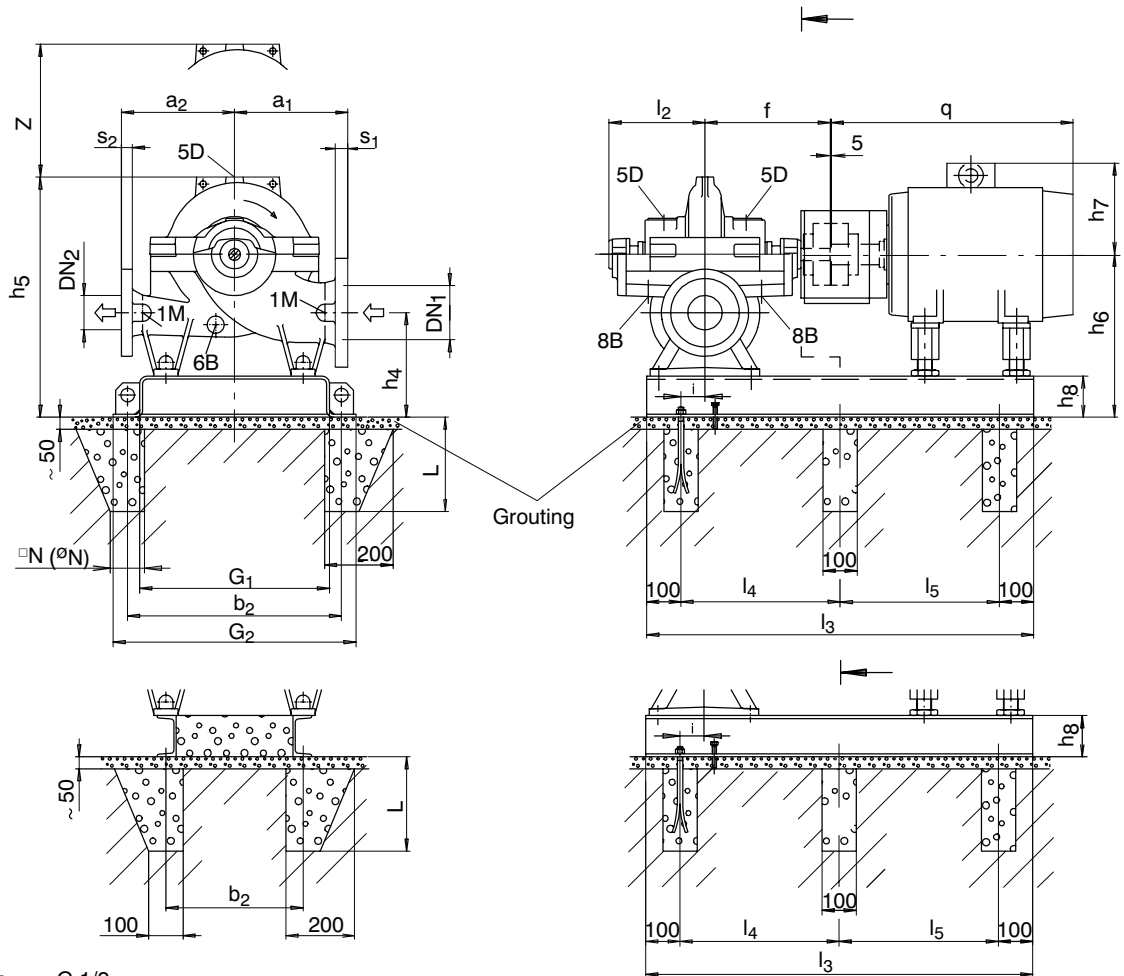

- Connections:
- 1M Pressure gauge G 1/2
  - 5D Vent G 1/2
  - 6B Drainage G 1/2
  - 8B Leakage liquid drain G 3/4

Grout baseplate / base frame with non-shrinking cement.  
Position of the terminal box, see "Motor dimension sheet".

The motor-dependent dimensions refer to KSB standard motors (see table "Motor dimensions and weights").

#### Major external pump dimensions and weights

all dimensions in mm

Pump size	motor-dependent	Flange dimensions				Pump dimensions									Weight [kg]	
		DN <sub>1</sub>	DN <sub>2</sub>	s <sub>1</sub>	s <sub>2</sub>	a <sub>1</sub> <sup>3)</sup>	a <sub>2</sub> <sup>3)</sup>	f	h <sub>4</sub>	h <sub>5</sub> max.	h <sub>6</sub>	i	l <sub>2</sub>	z <sup>2)</sup>	Pump	Water content
150-460	up to 250 M	200	150	41	37	450	450	590	320	1050	520	215	399	610	436	75
	280 S up tp 315 L					600	500		380		580				740	646
150-605	-										620					
200-320	up to 250 M	250	200	48	41	450	450	655	440	1240	680	150	399	570	450	80
	280 S, M					500	500		380		620				620	517
200-420	up to 250 M	250	200	48	41	500	500	655	440	1240	680	150	399	620	517	95
	280 S up to 315 L					600	500		380		680				620	517
200-520	250 M	250	200	48	41	600	500	655	440	1240	740	150	399	740	840	115
	up 280 S					650	550		430		780				860	140
200-670	-	250	200	48	41	650	550	655	430	1240	780	150	399	860	990	140
						420	500		480		720				780	640
250-370	250 M	300	250	33 (51) <sup>1)</sup>	32 (48) <sup>1)</sup>	500	500	655	420	1275	720	150	464	640	665	125
	up 280 S								480		500				480	780
300-300	up to 250 M	350	300	36 (54) <sup>1)</sup>	33 (51) <sup>1)</sup>	550	500	655	450	1430	750	150	464	720	630	100
	up 280 S								510		500				480	810

<sup>1)</sup> For casing material GGG-NiCrNb 202, JS 1030 1.4517

<sup>2)</sup> z = The dimensions to be maintained around the casing cover for dismantling of the rotor

<sup>3)</sup> material combinations SB and SC: dimensions are 1% larger

**Baseplate / base frame and foundation dimensions** all dimensions in mm

Baseplate size		Baseplate and foundation dimensions								Foundation bolts		
No	Drawing no.	b <sub>2</sub>	G <sub>1</sub>	G <sub>2</sub>	l <sub>3</sub>	l <sub>4</sub>	l <sub>5</sub>	h <sub>8</sub>	Weight [kg]	Size	N	L
7	OW 384 174-00	880	820	960	1660	730	730	120	157	M 20x320	100	320
8 <sup>1)</sup>	OW 384 175-00	700	620	750	1870	835	835	180	185			
9 <sup>1)</sup>	OW 384 176-00				1970	885	885		204			
10 <sup>1)</sup>	OW 384 478-00				2170	985	985		208			
14 <sup>1)</sup>	OW 384 479-00				2320	1060	1060		210			
15 <sup>1)</sup>	OW 384 480-00								215			

<sup>1)</sup> Base frame

**Standard Fflange design <sup>2)</sup>:**

Pump size	JL 1040 / GGG-NiCrNb 202 Nominal pressure acc. to:			JS 1030 / 1.4517 Nominal pressure acc. to:		
	DIN 2501 ISO 7005/2	BS 4504	ANSI B 16.1	DIN 2501 ISO 7005/2	BS 4504	ANSI B 16.1
150-460	PN 16	Table 16/11	Class 250	PN 25	Table 25/11	Class 250
150-605	PN 25	Table 25/11				
200-320	PN 16	Table 16/11				
200-420						
200-520	PN 25	Table 25/11				
200-670						
250-370	PN 10	Table 10/11	Class 125			
300-300						

<sup>2)</sup> Other flange designs are available on request

**Flange dimensions - Drilling diagram**

Norm	Suction flange				Discharge flange			
	DN	d <sub>2</sub>	k	n	DN	d <sub>2</sub>	k	n
Pump size 150-460 and 150-605	200				150			
ISO 7005/2, DIN 2501 BS 4504	PN 16 Table 16/11	23 (M20)	295	12	23 (M20)	240	8	
ISO 7005/2, DIN 2501 BS 4504		28 (M24)	310			250		
ANSI B 16.1		28 (M24)	330			270		12
Pump size 200-320 up to 200-670	250				200			
ISO 7005/2, DIN 2501 BS 4504	PN 16 Table 16/11	28 (M24)	355	12	23 (M20)	295	12	
ISO 7005/2, DIN 2501 BS 4504		31 (M27)	370			310		
ANSI B 16.1		28 (M24)	387			330		
Pump size 250-370	300				250			
ISO 7005/2, DIN 2501 BS 4504	PN 10 Table 10/11	23 (M20)	400	12	23 (M20)	350	12	
ISO 7005/2, DIN 2501 BS 4504		28 (M24)	410			355		
ISO 7005/2, DIN 2501 BS 4504	PN 16 Table 16/11	31 (M27)	430	16	31 (M27)	370	16	
ANSI B 16.1		28 (M24)	432			362		
ANSI B 16.1	Class 125	31 (M27)	451	20	28 (M24)	387	16	
ANSI B 16.1	Class 250				31 (M27)	451	16	
Pump size 300-300	350				300			
ISO 7005/2, DIN 2501 BS 4504	PN 10 Table 10/11	23 (M20)	460	16	23 (M20)	400	12	
ISO 7005/2, DIN 2501 BS 4504		28 (M24)	470			410		
ISO 7005/2, DIN 2501 BS 4504	PN 16 Table 16/11	34 (M30)	490	16	31 (M27)	430	16	
ANSI B 16.1		28 (M24)	476			432		
ANSI B 16.1	Class 125	31 (M27)	514	20	28 (M24)	432	12	
ANSI B 16.1	Class 250				31 (M27)	451	16	

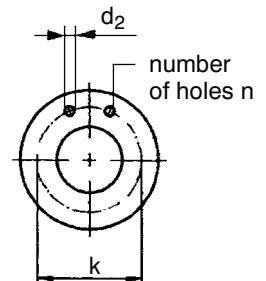
Mating flange  
All flanges designed as  
plate flanges

**N.B.**

- The numbers listed in the table indicate the relevant base plate numbers.
  - The baseplate numbers shown in the boxes also serve to select the correct motor size for the listed pump size.
  - Units comprising a motor size 315 and larger are completely assembled for verification and adjustment of the individual components.
- Before shipment, the units are dismantled again and the components packed / shipped separately.

**Baseplate / motor combination**

Pump size	Motor size												
	180L	200L	225S	225M	250M	280S	280M	315S	315M	315L	315	355	400
Number of poles	4	4	4	4	4	4	4	4	4	4	4	4	4
150-460		7	7	7	7	8	8	8	8	8			
150-605						8	8	8	8	9	9	14	
200-320	7	7	7	7	7	8	8						
200-420		7	7	7	7	8	8	8	8	9			
200-520					7	8	8	8	8	10	10	15	
200-670								8	8	10	10	15	15
250-370					7	8	8	8	8	10			
300-300		7	7	7	7	8	8	8					

**General arrangement drawing 250 - 480 up to 250 - 600; 300 - 435 and 350 - 360**

**Type of arrangement 3E**

Direction of rotation: CLOCKWISE

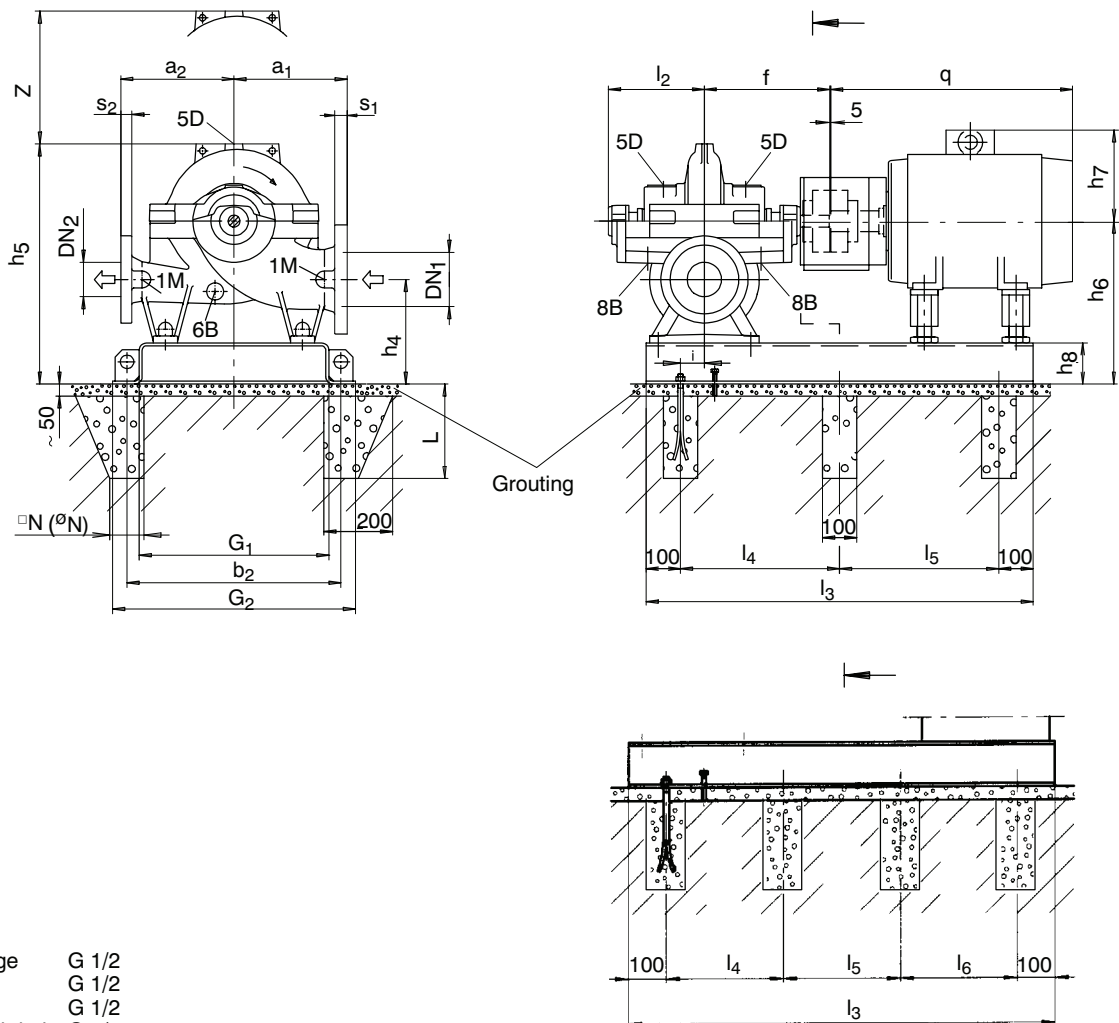

**Connections:**

- 1M Pressure gauge G 1/2
- 5D Vent G 1/2
- 6B Drainage G 1/2
- 8B Leakage liquid drain G 3/4

Grout baseplate / base frame with non-shrinking cement.  
Position of the terminal box, see "Motor dimension sheet".

The motor-dependent dimensions refer to KSB standard motors (see table "Motor dimensions and weights").

**Major external pump dimensions and weights**

all dimensions in mm

Pump size	Flange dimensions				Pump dimensions							Weight [kg]			
	DN <sub>1</sub>	DN <sub>2</sub>	s <sub>1</sub>	s <sub>2</sub>	a <sub>1</sub> <sup>3)</sup>	a <sub>2</sub> <sup>3)</sup>	f	h <sub>4</sub> <sup>3)</sup>	h <sub>5</sub> max.	h <sub>6</sub> <sup>3)</sup>	i	l <sub>2</sub>	z <sup>2)</sup>	Pump	Water content
250-480	300	250	51	48	550	550	730	500	1275	800	210	515	710	830	145
250-600					480			830		830				1215	180
300-435	400	300	38 (57) <sup>1)</sup>	33 (51) <sup>1)</sup>	650	550	730	520	1430	870	210	515	730	905	190
350-360		350		36 (54) <sup>1)</sup>									820	865	160

<sup>1)</sup> For casing material GGG-NiCrNb 202, JS 1030, 1.4517

<sup>2)</sup> z = the dimensions to be maintained around the casing cover for dismantling of the rotor

<sup>3)</sup> material combinations SB and SC: dimensions are 1% larger

**Baseplate / base frame and foundation dimensions**

all dimensions in mm

Baseplate size Drawing no.	Baseplate and foundation dimensions									Foundation bolts		
	b <sub>2</sub>	G <sub>1</sub>	G <sub>2</sub>	l <sub>3</sub>	l <sub>4</sub>	l <sub>5</sub>	l <sub>6</sub>	h <sub>8</sub>	Weight [kg]	Größe	□N	L
11 <sup>4)</sup> 0W 384 177-00	700	620	760	1950	875	-	-	200	215	M 20x320	100	320
12 <sup>4)</sup> 0W 384 178-00				2100	950	-	228					
16 <sup>4)</sup> 0W 384 481-00				2450	750	750	240					

<sup>4)</sup> Base frame

**Standard flange design <sup>1)</sup>:**

Pump size	JL 1040 / GGG-NiCrNb 202 Nominal pressure acc. to:			JS 1030 / 1.4517 Nominal pressure acc. to:		
	DIN 2501 ISO 7005/2	BS 4504	ANSI B 16.1	DIN 2501 ISO 7005/2	BS 4504	ANSI B 16.1
250-480	PN 16	Table 16/11	Class 250	PN 25	Table 25/11	Class 250
250-600	PN 25	Table 25/11				
300-435	PN 10	Table 10/11	Class 125			
350-360						

<sup>1)</sup> Other flange designs are available on request

**Flange dimensions - Drilling diagram**

all dimensions in mm

Standard	Suction flange				Discharge flange			
	DN	d <sub>2</sub>	k	n	DN	d <sub>2</sub>	k	n
Pump size 250-480 and 250-600	300				250			
ISO 7005/2 DIN 2501 BS 4504	PN 10 Table 10/11	23 (M20)	400	12	23 (M20)	350	12	
ISO 7005/2 DIN 2501 BS 4504	PN 16 Table 16/11	28 (M24)	410		28 (M24)	355		
ISO 7005/2 DIN 2501 BS 4504	PN 25 Table 25/11	31 (M27)	430	16	31 (M27)	370		
ANSI B 16.1	Class 125	28 (M24)	432	12	28 (M24)	362		
ANSI B 16.1	Class 250	31 (M27)	451	16	28 (M24)	387	16	
Pump size 300-435	400				300			
ISO 7005/2 DIN 2501 BS 4504	PN 10 Table 10/11	28 (M24)	515	16	23 (M20)	400	12	
ISO 7005/2 DIN 2501 BS 4504	PN 16 Table 16/11	31 (M27)	525		28 (M24)	410		
ISO 7005/2 DIN 2501 BS 4504	PN 25 Table 25/11	37 (M33)	550		16	31 (M27)	430	16
ANSI B 16.1	Class 125	28 (M24)	540	12	28 (M24)	432	12	
ANSI B 16.1	Class 250	34	572	20	31 (M27)	451	16	
Pump size 350-360	400				350			
ISO 7005/2 DIN 2501 BS 4504	PN 10 Table 10/11	28 (M24)	515	16	23 (M20)	460	16	
ISO 7005/2 DIN 2501 BS 4504	PN 16 Table 16/11	31 (M27)	525	16	28 (M24)	470		
ISO 7005/2 DIN 2501 BS 4504	PN 25 Table 25/11	37 (M33)	550	16	34 (M30)	490		
ANSI B 16.1	Class 125	28 (M24)	540	16	28 (M24)	476	12	
ANSI B 16.1	Class 250	34	572	20	31 (M27)	514	20	

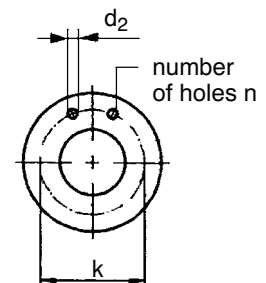
 Mating flange  
 All flanges designed as plate flanges

**Baseplate / motor combination**

Pump size	Motor size								
	250M	280S	280M	315S	315M	315L	315	355	400
Number of poles	4	4	4	4	4	4	4	4	4
250-480	11	11	11	11	11	12	12	16	
250-600					11	12	12	16	16
300-435			11	11	11	12	12		
350-360	11	11	11	11	11	12	12		

 N.B.: - The numbers listed in the table indicate the relevant baseplate numbers.  
 - The baseplate numbers shown in the boxes also serve to select the correct motor size for the listed pump size.

- Units comprising a motor size 315 and larger are completely assembled for verification and adjustment of the individual components. Before shipment, the units are dismantled again and the components packed / shipped separately.

**General arrangement drawing Omega 300 - 560 up to 300 - 700; 350 - 430 and 350 - 510**

**Type of arrangement 3E**

Direction of rotation: CLOCKWISE

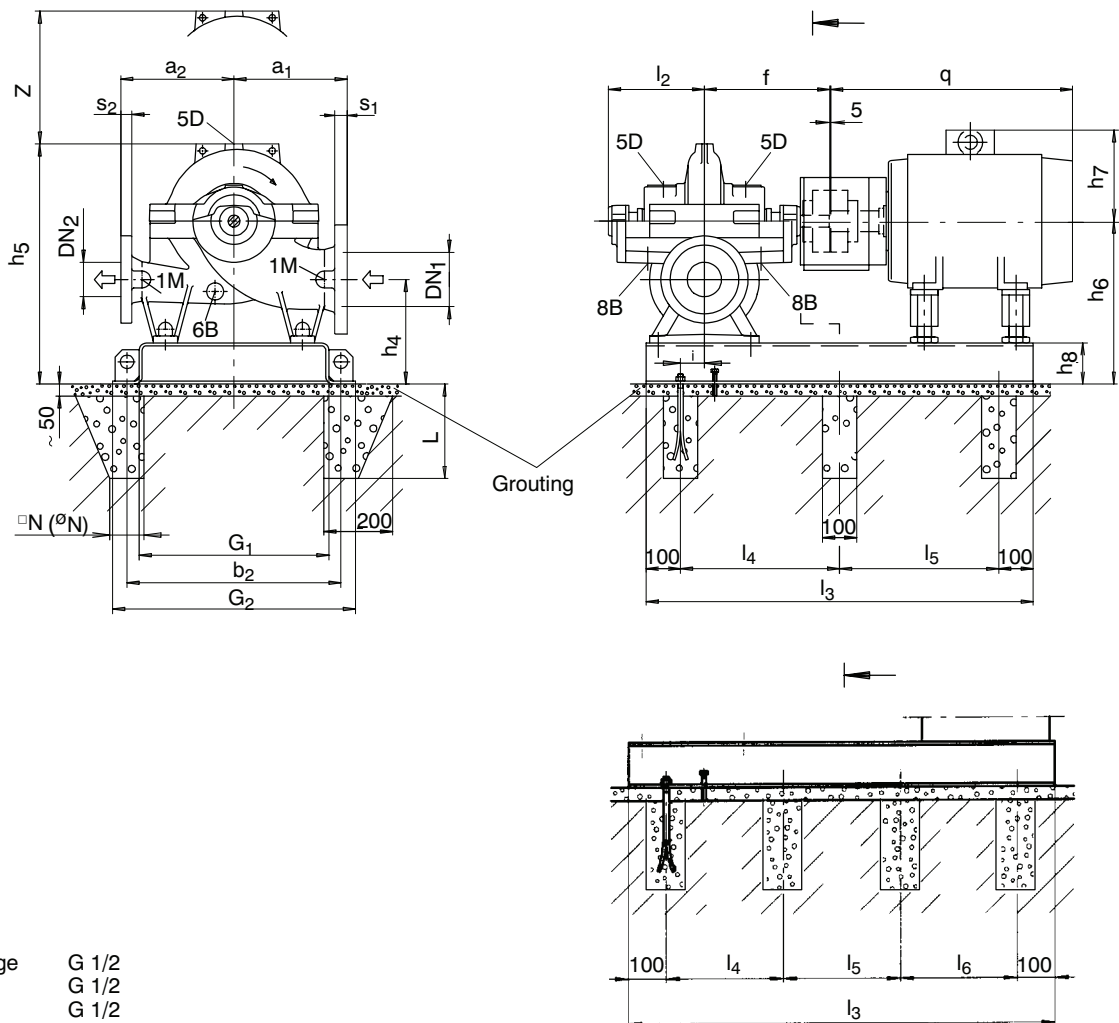

**Connections:**

- 1M Pressure gauge G 1/2
- 5D Vent G 1/2
- 6B Drainage G 1/2
- 8B Leakage liquid drain G 3/4

Grout baseplate / base frame with non-shrinking cement.  
Position of the terminal box. see "Motor dimension sheet".

The motor-dependent dimensions refer to KSB standard motors (see table "Motor dimensions and weights").

**Major external pump dimensions and weights**

all dimensions in mm

Pump size	Flange dimensions				Pump dimensions							Weight [kg]			
	DN <sub>1</sub>	DN <sub>2</sub>	s <sub>1</sub>	s <sub>2</sub>	a <sub>1</sub> <sup>3)</sup>	a <sub>2</sub> <sup>3)</sup>	f	h <sub>4</sub> <sup>3)</sup>	h <sub>5</sub> max.	h <sub>6</sub> <sup>3)</sup>	i	l <sub>2</sub>	z <sup>2)</sup>	Pump	Water content
300-560	400	300	57	51	700	650	810	560	1430	910	210	585	860	1425	225
300-700					750								960	1690	275
350-430	450	350	41 (60) <sup>1)</sup>	36 (54) <sup>1)</sup>	700	650	810	550	1415	950	210	585	930	1285	240
350-510	400		38 (57) <sup>1)</sup>		700								840	1395	290

<sup>1)</sup> For casing material GGG-NiCrNb 202, JS 1030, 1.4517

<sup>2)</sup> z = The dimensions to be maintained around the casing cover for dismantling of the rotor

<sup>3)</sup> material combinations SB and SC: dimensions are 1% larger

**Baseplate / base frame and foundation dimensions**

all dimensions in mm

Baseplate size	Baseplate and foundation dimensions									Foundation bolts			
	No Drawing no.	b <sub>2</sub>	G <sub>1</sub>	G <sub>2</sub>	l <sub>3</sub>	l <sub>4</sub>	l <sub>5</sub>	l <sub>6</sub>	h <sub>8</sub>	Weight [kg]	Größe	□N	L
13 <sup>4)</sup>	0W 384 179-00	950	870	1010	2195	665		200	290	322	M 20x320	100	320
17 <sup>4)</sup>					2540	780							
18 <sup>4)</sup>					2390	730							
0W 384 482-00													
0W 384 483-00													

<sup>4)</sup> Base frame

**Standard flange design <sup>1)</sup>:**

Pump size	JL 1040 / GGG-NiCrNb 202 Nominal pressure acc. to:			JS 1030 / 1.4517 Nominal pressure acc. to:		
	DIN 2501 ISO 7005/2	BS 4504	ANSI B 16.1	DIN 2501 ISO 7005/2	BS 4504	ANSI B 16.1
300-560	PN 16	Table 16/11	Class 250	PN 25	Table 25/11	Class 250
300-700	PN 25	Table 25/11				
350-430	PN 10	Table 10/11	Class 125			
350-510						

<sup>1)</sup> Other flange designs are available on request

**Flange dimensions - Drilling diagram**

all dimensions in mm

Standard	Suction flange				Discharge flange			
	DN	d <sub>2</sub>	k	n	DN	d <sub>2</sub>	k	n
Pump size 300-560 and 300-700	400				300			
ISO 7005/2 DIN 2501 BS 4504	PN 10 Table 10/11	28 (M24)	515	16	23 (M20)	400	12	16
ISO 7005/2 DIN 2501 BS 4504	PN 16 Table 16/11	31 (M27)	525		28 (M24)	410		
ISO 7005/2 DIN 2501 BS 4504	PN 25 Table 25/11	37 (M33)	550		31 (M27)	430		
ANSI B 16.1	Class 125	28 (M24)	540		28 (M24)	432	12	
ANSI B 16.1	Class 250	34	572	20	31 (M27)	451	16	
Pump size 350-430	450				350			
ISO 7005/2 DIN 2501 BS 4504	PN 10 Table 10/11	28 (M24)	565	20	23 (M20)	460	16	16
ISO 7005/2 DIN 2501 BS 4504	PN 16 Table 16/11	31 (M27)	585		28 (M24)	470		
ISO 7005/2 DIN 2501 BS 4504	PN 25 Table 25/11	37 (M33)	600		34 (M30)	490		
ANSI B 16.1	Class 125	31 (M27)	578	16	28 (M24)	476	12	
ANSI B 16.1	Class 250	34	629	24	31 (M27)	514	20	
Pump size 350-510	400				350			
ISO 7005/2 DIN 2501 BS 4504	PN 10 Table 10/11	28 (M24)	515	16	23 (M20)	460	16	16
ISO 7005/2 DIN 2501 BS 4504	PN 16 Table 16/11	31 (M27)	525		28 (M24)	470		
ISO 7005/2 DIN 2501 BS 4504	PN 25 Table 25/11	37 (M33)	550		34 (M30)	490		
ANSI B 16.1	Class 125	28 (M24)	540		28 (M24)	476	12	
ANSI B 16.1	Class 250	34	572	20	31 (M27)	514	20	

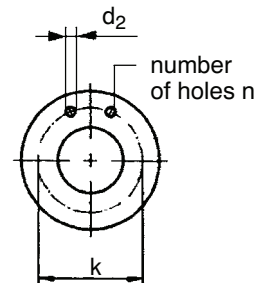
 Mating flange  
 All flanges designed as plate flanges

**Baseplate / motor combination**

Pump size	Motor size				
	315M	315L	315	355	400
Number of poles	4	4	4	4	4
300-560	13	13	13	17	17
300-700			13	18	17
350-430	13	13	13	18	
350-510		13	13	18	17

 N.B.:
 

- The numbers listed in the table indicate the relevant baseplate numbers.
- The baseplate numbers shown in the boxes also serve to select the correct motor size for the listed pump size.

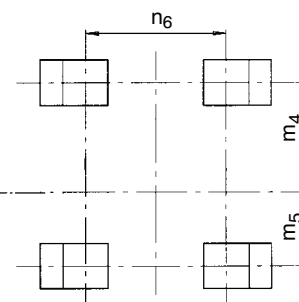
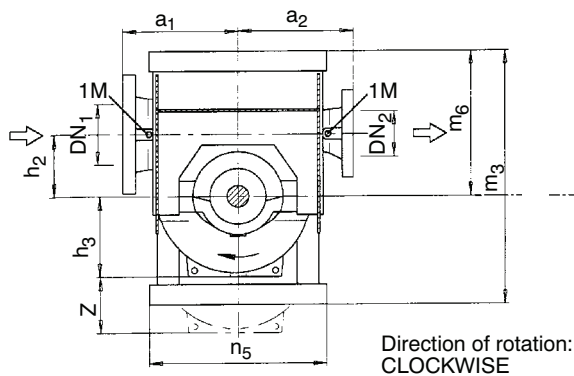
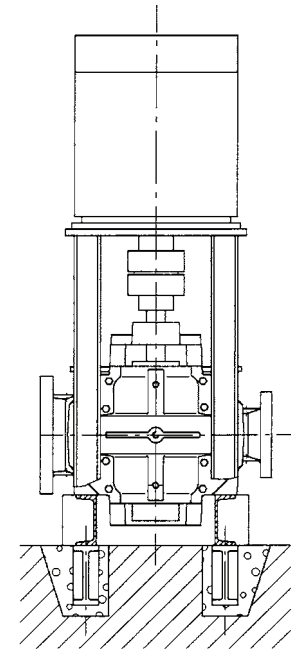
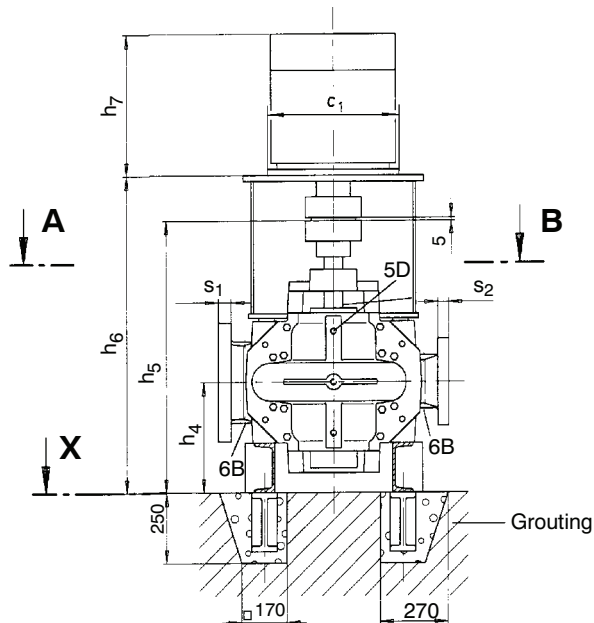
- Units comprising a motor size 315 and larger are completely assembled for verification and adjustment of the individual components. Before shipment, the units are dismantled again and the components packed / shipped separately.

**General arrangement drawing Omega V 80 - 210 up to 80 - 370**
**Type of arrangement DB**
**Type of arrangement DK**

**View X**
**Section A - B**

Permissible deviations for:

- Centreline heights           DIN 747
- Dimensions without indication  
  of tolerances               DIN 7168, medium
- Cast iron parts               DIN 1686 GTB 18

Connections:

- 1M   Pressure gauge       G 1/2
- 5D   Vent                 G 1/2
- 6B   Drainage             G 1/2
- 8B   Leakage liquid drain G 3/4

Flanges:

- Flat surface flanges
- Flange thickness to ANSI
- Connect pipes without stress

 Position of the terminal box to be in accordance  
with motor dimension sheet

**Major external pump dimensions and weights**

all dimensions in mm

Pump size	Flange dimensions				Pump dimensions							Weights [kg]	
	DN <sub>1</sub>	DN <sub>2</sub>	s <sub>1</sub>	s <sub>2</sub>	a <sub>1</sub> <sup>2)</sup>	a <sub>2</sub> <sup>2)</sup>	h <sub>2</sub>	h <sub>3</sub>	h <sub>4</sub>	h <sub>5</sub>	z <sup>1)</sup>	Pump	Water content
80-210	125	80	34	29	300	300	140	168	300	715	340	185	10
190													
225													
80-270	125	80	34	29	300	300	140	190	300	715	380	195	15
225													
250													
80-370	125	80	34	29	300	300	140	225	300	715	450	205	20
250													
270													

1) z = the dimensions to be maintained around the casing cover for dismantling of the rotor

2) material combinations SB and SC: dimensions are 1% larger

**Standard flange design <sup>1)</sup>:**

Pump size	JL 1040 / GGG-NiCrNb 202 Nominal pressure acc. to:			JS 1030 / 1.4517 Nominal pressure acc. to:		
	DIN 2501 ISO 7005/2	BS 4504	ANSI B 16.1	DIN 2501 ISO 7005/2	BS 4504	ANSI B 16.1
80-210	PN 16	Table 16/11	Class 250	PN 25	Table 25/11	Class 250
80-270						
80-370						

<sup>1)</sup> Other flange designs are available on request

**Flange dimensions - Drilling diagram** all dimensions in mm

Standard		Suction flange DN 125			Discharge flange DN 80		
		d <sub>2</sub>	k	n	d <sub>2</sub>	k	n
ISO 7005/2 DIN 2501	PN 16	19	210	8	19	160	8
ISO 7005/2 DIN 2501	PN 25	28	220				
BS 4504	Table 16/11	19	210				
BS 4504	Table 25/11	28	220				
ANSI B 16.1	Class 250	23	235				

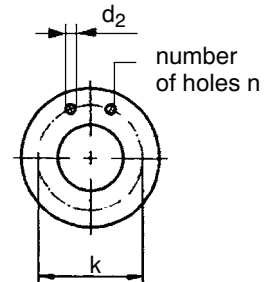
**Motor dimensions and weights IEC-Motors, IP 55 <sup>2)</sup>**

all dimensions in mm

Pump size	Type of arrangement		Motor size	c <sub>1</sub>	h <sub>6</sub>	h <sub>7</sub>	m <sub>3</sub>	m <sub>4</sub>	m <sub>5</sub>	m <sub>6</sub>	n <sub>5</sub>	n <sub>6</sub>	Weight of motor [kg]
	DB	DK											
80-210	●	--	min. 100 L	250	780	315	640	275	100	380	450	340	15
			max. 200 L	400	830	665							250
	--	●	min. 225 M	450	830	695	720						330
			max. 250 M	550		860							790
80-270	●	--	min. 100 L	250	780	315	640	275	100	380	450	340	25
			max. 200 L	400	830	665							250
	--	●	min. 225 M	450	830	695	720						330
			max. 315 S	660		860							970
80-370	●	--	min. 132 S	300	800	375	640	275	100	380	450	340	45
			max. 200 L	400	830	665							250

<sup>2)</sup> Dimension and weight deviations subject to selected motor manufacturer are to be considered

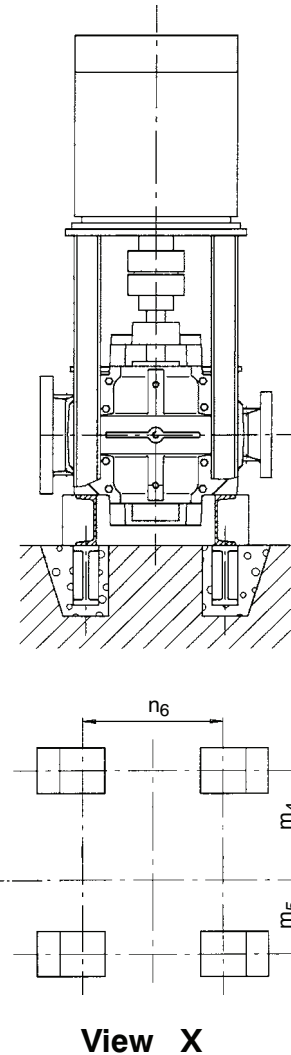
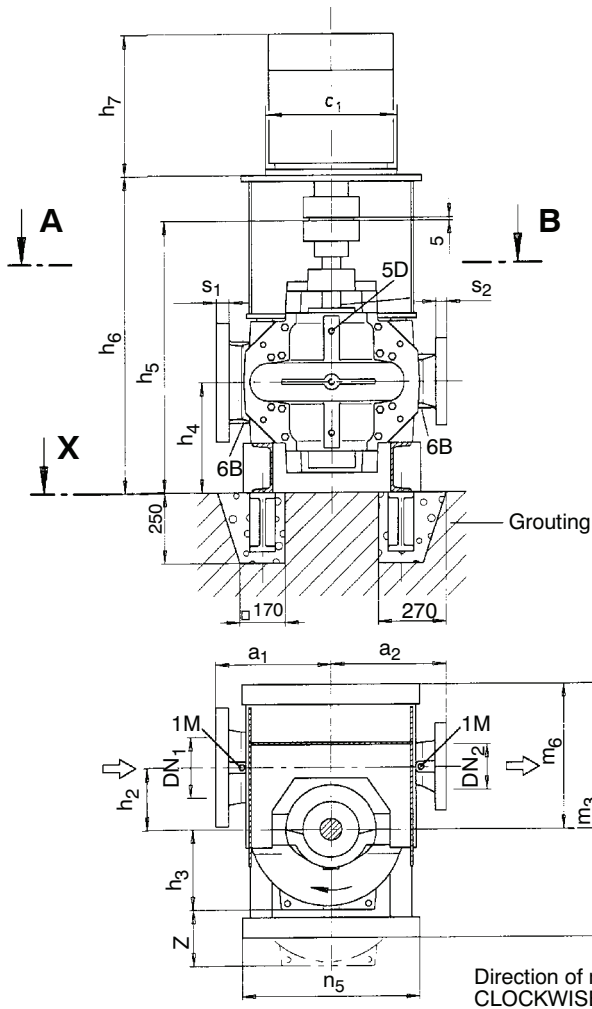
**General arrangement drawing Omega V 100 - 250 up to 100 - 375**
**Type of arrangement DB**
**Type of arrangement DK**

**Section A - B**
**View X**

Permissible deviations for:

- Centreline heights           DIN 747
- Dimensions without indication of tolerances   DIN 7168, medium
- Cast iron parts                DIN 1686 GTB 18

Connections:

- 1M   Pressure gauge    G 1/2
- 5D   Vent                G 1/2
- 6B   Drainage           G 1/2
- 8B   Leakage liquid drain G 3/4

Flanges:

- Flat surface flanges
- Flange thickness to ANSI
- Connect pipes without stress

Position of the terminal box to be in accordance with motor dimension sheet

**Major external pump dimensions and weights**

all dimensions in mm

Pump size	Flange dimensions				Pump dimensions							Weights ([kg])	
	DN <sub>1</sub>	DN <sub>2</sub>	s <sub>1</sub>	s <sub>2</sub>	a <sub>1</sub> <sup>2)</sup>	a <sub>2</sub> <sup>2)</sup>	h <sub>2</sub>	h <sub>3</sub>	h <sub>4</sub>	h <sub>5</sub>	z <sup>1)</sup>	Pump	Water content
100-250	150	100	37	32	330	330	170	195	300	715	390	210	20
100-310								225				225	
100-375								260				245	30

1) z = the dimensions to be maintained around the casing cover for dismantling of the rotor

2) material combinations SB and SC: dimensions are 1% larger

**Standard flange design <sup>1)</sup>:**

Pump size	JL 1040/ GGG-NiCrNb 202 Nominal pressure acc. to:			JS 1030 / 1.4517 Nominal pressure acc. to:		
	DIN 2501 ISO 7005/2	BS 4504	ANSI B 16.1	DIN 2501 ISO 7005/2	BS 4504	ANSI B 16.1
100-250	PN 16	Table 16/11	Class 250	PN 25	Table 25/11	Class 250
100-310						
100-375						

<sup>1)</sup> Other flange designs are available on request

**Flange dimensions - Drilling diagram** all dimensions in mm

Standard		Suction flange DN 150			Discharge flange DN 100		
		d <sub>2</sub>	k	n	d <sub>2</sub>	k	n
ISO 7005/2 DIN 2501	PN 16	23	240	8	19	180	8
ISO 7005/2 DIN 2501	PN 25	28	250		23	190	
BS 4504	Table 16/11	23	240		19	180	
BS 4504	Table 25/11	28	250		23	190	
ANSI B 16.1	Class 250	23	270	12	200		

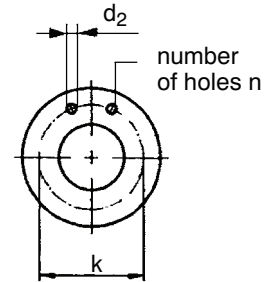
**Motor dimensions and weights IEC-Motors, IP 55 <sup>2)</sup>**

all dimensions in mm

Pump size	Type of arrangement		Motor size	c <sub>1</sub>	h <sub>6</sub>	h <sub>7</sub>	m <sub>3</sub>	m <sub>4</sub>	m <sub>5</sub>	m <sub>6</sub>	n <sub>5</sub>	n <sub>6</sub>	Weight of motor [kg]
	DB	DK											
100-250	●	--	min. 100 L	250	780	315	695				500		25
			max. 225 M	450	830	695							330
	--	●	min. 250 M	550	860	790	760				810		435
			max. 315 M	660		970							850
100-310	●	--	min. 132 M	300	800	375	695				500		55
			max. 225 M	450	830	695							330
	--	●	min. 250 M	550	860	790	760	315	115	420	810	400	435
			max. 315	800		1230							1500
100-375	●	--	min. 160 M	350	830	481	695				500		75
			max. 225 M	450		695							330
	--	●	min. 250 M	550	860	790	760				810		435
			max. 280 S			865							610

<sup>2)</sup> Dimension and weight deviations subject to selected motor manufacturer are to be considered

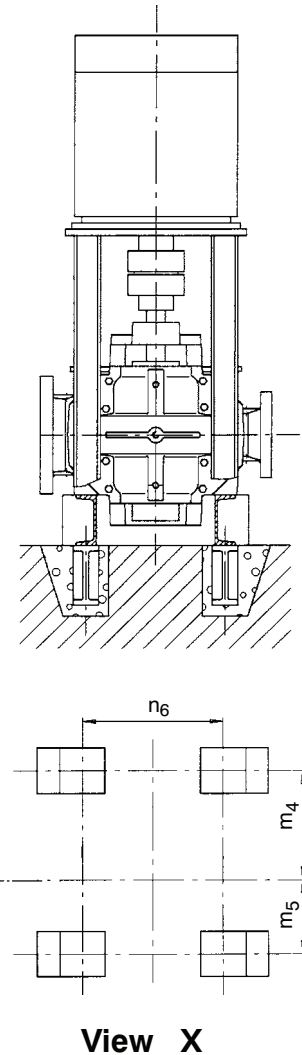
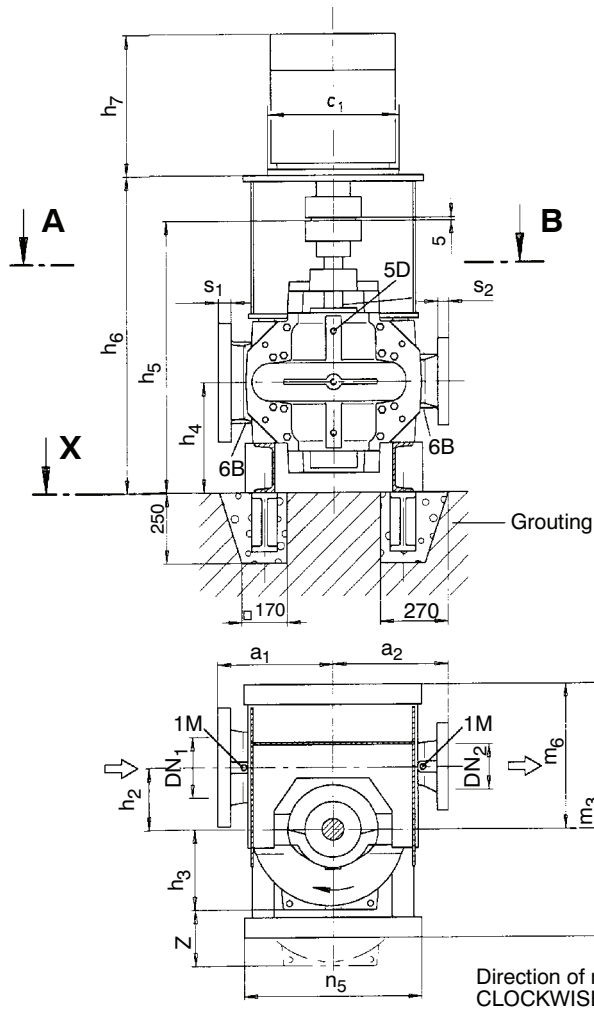
**General arrangement drawing Omega V 125 - 230 up to 125 - 500**
**Type of arrangement DB**
**Type of arrangement DK**

**Section A - B**
**View X**

 Direction of rotation:  
**CLOCKWISE**

Permissible deviations for:

- Centreline heights           DIN 747
- Dimensions without indication  
of tolerances           DIN 7168, medium
- Cast iron parts           DIN 1686 GTB 18

Connections:

- 1M   Pressure gauge       G 1/2
- 5D   Vent                 G 1/2
- 6B   Drainage             G 1/2
- 8B   Leakage liquid drain G 3/4

Flanges:

- Flat surface flanges
- Flange thickness to ANSI
- Connect pipes without stress

 Position of the terminal box to be in accordance  
 with motor dimension sheet

**Major external pump dimensions and weights**

all dimensions in mm

Pump size	Flange dimensions				Pump dimensions							Weights [kg]	
	DN <sub>1</sub>	DN <sub>2</sub>	s <sub>1</sub>	s <sub>2</sub>	a <sub>1</sub> <sup>2)</sup>	a <sub>2</sub> <sup>2)</sup>	h <sub>2</sub>	h <sub>3</sub>	h <sub>4</sub>	h <sub>5</sub>	z <sup>1)</sup>	Pump	Water content
125-230	200	125	41	35	370	370	200	210	355	870	420	250	35
125-290								230				275	40
125-365								260				300	45
125-500								305				335	55

<sup>1)</sup> z = The dimensions to be maintained around the casing cover for dismantling of the rotor

<sup>2)</sup> material combinations SB and SC: dimensions are 1% larger

**Standard flange design <sup>1)</sup>:**

Pump size	JL 1040 / GGG-NiCrNb 202 Nominal pressure acc. to:			JS 1030 / 1.4517 Nominal pressure acc. to:		
	DIN 2501 ISO 7005/2	BS 4504	ANSI B 16.1	DIN 2501 ISO 7005/2	BS 4504	ANSI B 16.1
125-230	PN 16	Table 16/11	Class 250	PN 25	Table 25/11	Class 250
125-290						
125-365						
125-500						

<sup>1)</sup> Other flange designs are available on request

**Flange dimensions - Drilling diagram** all dimensions in mm

Standard		Suction flange DN 200			Discharge flange DN 125		
		d <sub>2</sub>	k	n	d <sub>2</sub>	k	n
ISO 7005/2 DIN 2501	PN 16	23	295	12	19	210	8
ISO 7005/2 DIN 2501	PN 25	28	310		28	220	
BS 4504	Table 16/11	23	295		19	210	
BS 4504	Table 25/11	28	310		28	220	
ANSI B 16.1	Class 250	28	330		23	235	

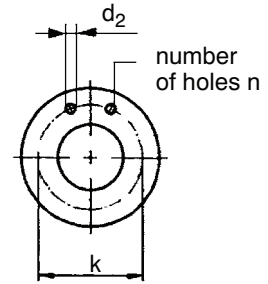
**Motor dimensions and weights IEC-Motors, IP 55 <sup>2)</sup>**

all dimensions in mm

Pump size	Type of arrangement		Motor size	c <sub>1</sub>	h <sub>6</sub>	h <sub>7</sub>	m <sub>3</sub>	m <sub>4</sub>	m <sub>5</sub>	m <sub>6</sub>	n <sub>5</sub>	n <sub>6</sub>	Weight of motor [kg]
	DB	DK											
125-230	•	--	min. 132 S	300	955	415	855				600		45
			max. 280 M	550		865							660
	--	•	min. 315 S	660	1015	970	820				860		830
			max. 315 M			850							
125-290	•	--	min. 132 M	300	955	415	855				600	450	55
			max. 280 M	550		865							660
	--	•	min. 315 S	660	1015	970	905	360	210	475	920		830
			max. 315			800							1230
125-365	•	--	min. 160 L	350	985	525	855				600		90
			max. 280 M	550		865							660
125-500	•	--	min. 200 L	400	985	610	855				700	560	170
			max. 315 M	660		970							910

<sup>2)</sup> Dimension and weight deviations subject to selected motor manufacturer are to be considered

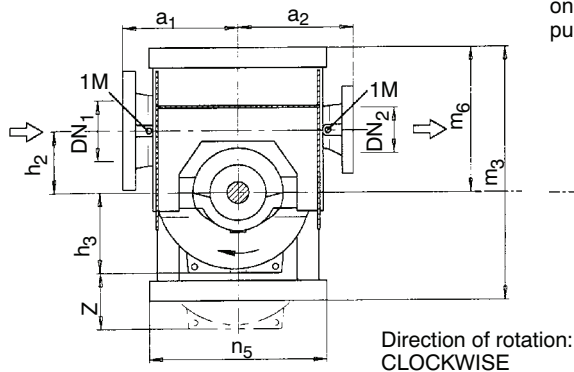
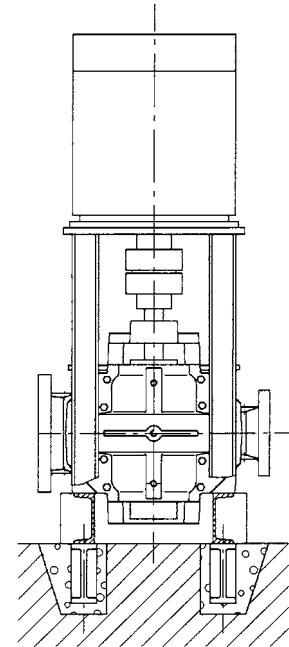
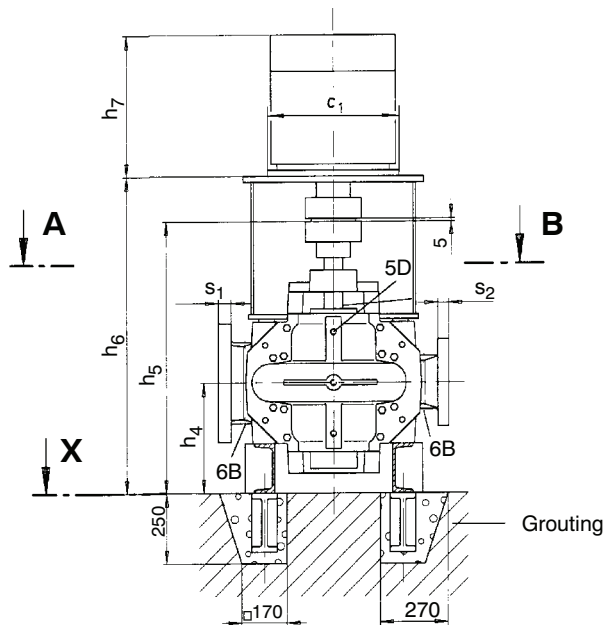
**General arrangement drawing Omega V 150 - 290 up to 150 - 605**
**Type of arrangement DB**
**Type of arrangement DK**

only for pump size 150-605

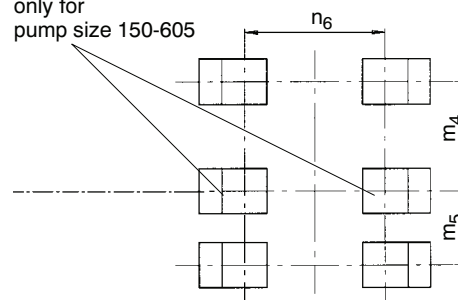
**View X**
**Section A - B**

Permissible deviations for:

- Centreline heights           DIN 747
- Dimensions without indication of tolerances   DIN 7168, medium
- Cast iron parts               DIN 1686 GTB 18

Connections:

- 1M   Pressure gauge    G 1/2
- 5D   Vent               G 1/2
- 6B   Drainage           G 1/2
- 8B   Leakage liquid drain G 3/4

Flanges:

- Flat surface flanges
- Flange thickness to ANSI
- Connect pipes without stress

Position of the terminal box to be in accordance with motor dimension sheet

**Major external pump dimensions and weights**

all dimensions in mm

Pump size	Flange dimensions				Pump dimensions							Weights [kg]	
	DN <sub>1</sub>	DN <sub>2</sub>	s <sub>1</sub>	s <sub>2</sub>	a <sub>1</sub> <sup>2)</sup>	a <sub>2</sub> <sup>2)</sup>	h <sub>2</sub>	h <sub>3</sub>	h <sub>4</sub>	h <sub>5</sub>	z <sup>1)</sup>	Pump	Water content
150-290	200	150	41	37	400	400	200	245	355	870	490	350	50
265								530				60	
305								400	990	440	75		
600										500	300	370	740

1) z = the dimensions to be maintained around the casing cover for dismantling of the rotor

2) material combinations SB and SC: dimensions are 1% larger

**Standard flange design <sup>1)</sup>:**

Pump size	JL 1040 / GGG-NiCrNb 202 Nominal pressure acc. to:			JS 1030 / 1.4517 Nominal pressure acc. to:		
	DIN 2501 ISO 7005/2	BS 4504	ANSI B 16.1	DIN 2501 ISO 7005/2	BS 4504	ANSI B 16.1
150-290	PN 16	Table 16/11	Class 250	PN 25	Table 25/11	Class 250
150-360						
150-460						
150-605	PN 25	Table 25/11				

<sup>1)</sup> Other flange designs are available on request

**Flange dimensions - Drilling diagram** all dimensions in mm

Standard		Suction flange DN 200			Discharge flange DN 150		
		d <sub>2</sub>	k	n	d <sub>2</sub>	k	n
ISO 7005/2 DIN 2501	PN 16	23	295	12	23	240	8
ISO 7005/2 DIN 2501	PN 25	28	310		28	250	
BS 4504	Table 16/11	23	295		23	240	
BS 4504	Table 25/11	28	310		28	250	
ANSI B 16.1	Class 250	28	330		23	270	

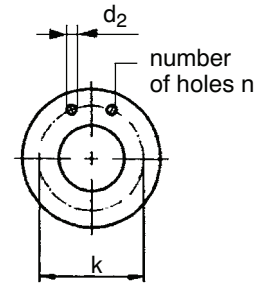
**Motor dimensions and weights IEC-Motors, IP 55 <sup>2)</sup>**

all dimensions in mm

Pump size	Type of arrangement		Motor size	c <sub>1</sub>	h <sub>6</sub>	h <sub>7</sub>	m <sub>3</sub>	m <sub>4</sub>	m <sub>5</sub>	m <sub>6</sub>	η <sub>5</sub>	η <sub>6</sub>	Weight of motor [kg]
	DB	DK											
150-290	•	--	min. 160 L	350	985	485	855	360	210	475	600	450	93
			max. 225 M	450	1015	695							330
150-360	•	--	min. 160 L	350	985	485							90
			max. 280 M	550	1015	695							
150-460	•	--	min. 200 L	400	1105	665					240		
			max. 315 L	660	1165	1110						1200	
150-605	•	--	min. 280 S	550	1135	865	610						
			max. 355	900	1165	1455		2200					
							1060	460	315	575	900	700	

<sup>2)</sup> Dimension and weight deviations subject to selected motor manufacturer are to be considered

General arrangement drawing Omega V 200 - 320 up to 200 - 670

Type of arrangement DB

Type of arrangement DK

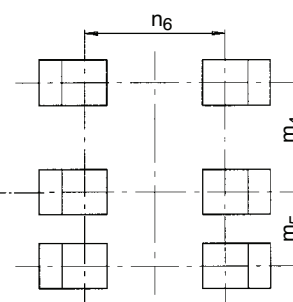
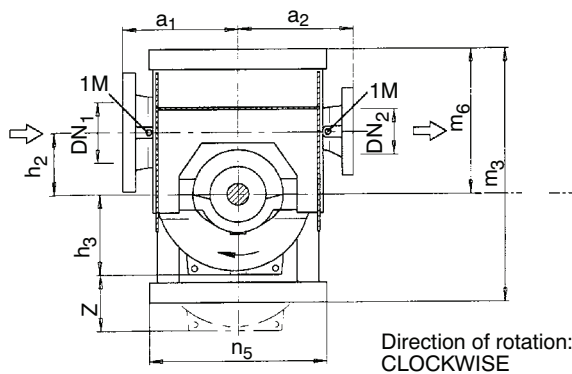
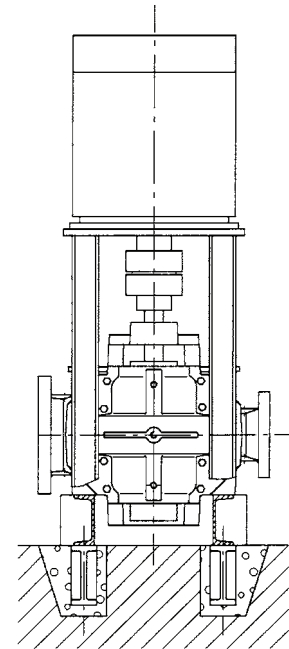
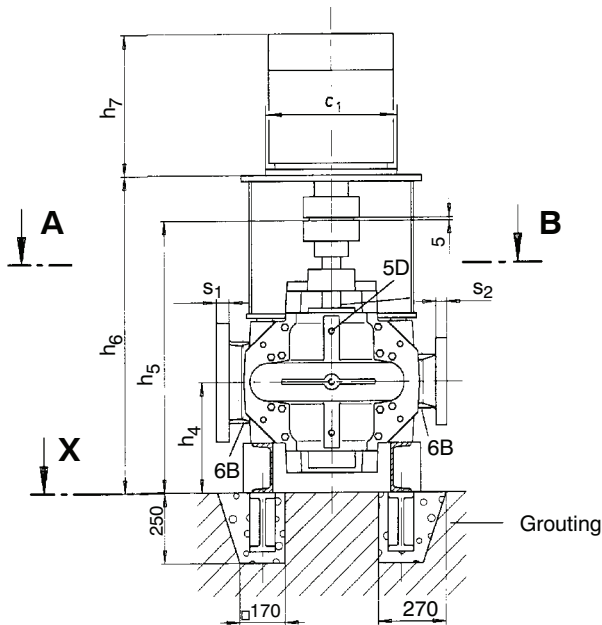

View X

Section A - B

Permissible deviations for:  
 - Centreline heights DIN 747  
 - Dimensions without indication of tolerances DIN 7168, medium  
 - Cast iron parts DIN 1686 GTB 18

Connections:  
 - 1M Pressure gauge G 1/2  
 - 5D Vent G 1/2  
 - 6B Drainage G 1/2  
 - 8B Leakage liquid drain G 3/4

Flanges:  
 - Flat surface flanges  
 - Flange thickness to ANSI  
 - Connect pipes without stress

Position of the terminal box to be in accordance with motor dimension sheet

Major external pump dimensions and weights

all dimensions in mm

Pump size	Flange dimensions				Pump dimensions							Weights (kg)	
	DN <sub>1</sub>	DN <sub>2</sub>	s <sub>1</sub>	s <sub>2</sub>	a <sub>1</sub> <sup>2)</sup>	a <sub>2</sub> <sup>2)</sup>	h <sub>2</sub>	h <sub>3</sub>	h <sub>4</sub>	h <sub>5</sub>	z <sup>1)</sup>	Pump	Water content
200-320	250	200	48	41	450	450	240	285	400	990	570	450	80
200-420					500	500		310				620	520
200-520					600	370	440	740	840	115			
200-670					650	430	1095	860	990	180			

<sup>1)</sup> z = the dimensions to be maintained around the casing cover for dismantling of the rotor

<sup>2)</sup> material combinations SB and SC: dimensions are 1% larger

**Standard flange design <sup>1)</sup>:**

Pump size	JL 1040 / GGG-NiCrNb 202 Nominal pressure acc. to:			JS 1030 / 1.4517 Nominal pressure acc. to:		
	DIN 2501 ISO 7005/2	BS 4504	ANSI B 16.1	DIN 2501 ISO 7005/2	BS 4504	ANSI B 16.1
200-320	PN 16	Table 16/11	Class 250	PN 25	Table 25/11	Class 250
200-420						
200-520						
200-670	PN 25	Table 25/11				

<sup>1)</sup> Other flange designs are available on request

**Flange dimensions - Drilling diagram** all dimensions in mm

Standard		Suction flange DN 250			Discharge flange DN 200		
		d <sub>2</sub>	k	n	d <sub>2</sub>	k	n
ISO 7005/2 DIN 2501	PN 16	28	355	12	23	295	12
ISO 7005/2 DIN 2501	PN 25	31	370		28	310	
BS 4504	Table 16/11	28	355		23	295	
BS 4504	Table 25/11	31	370			310	
ANSI B 16.1	Class 250	28	387		16	28	

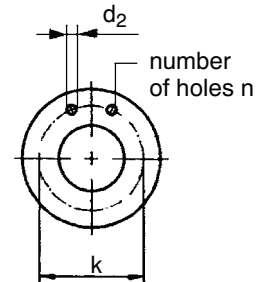
**Motor dimensions and weights IEC-Motors, IP 55 <sup>2)</sup>**

all dimensions in mm

Pump size	Type of arrangement		Motor size	c <sub>1</sub>	h <sub>6</sub>	h <sub>7</sub>	m <sub>3</sub>	m <sub>4</sub>	m <sub>5</sub>	m <sub>6</sub>	η <sub>5</sub>	η <sub>6</sub>	Weight of motor [kg]
	DB	DK											
200-320	•	--	min. 180 L	350	1105	995	1060	460	315	575	700	560	180
			max. 280 M	550	1135	865							660
200-420	•	--	min. 200 L	400	1105	665	1120	520	315	635	900	700	240
			max. 315 L	660	1135	1110							1200
200-520	•	--	min. 250 M	550	1200	790	1180	560	315	635	900	700	435
			max. 355	900		1455							2200
200-670	•	--	min. 315 S	660	1270	1110	1180	560	315	685	900	700	830
			max. 355	900		1455							2200
	--	•	min. 400	1000	1310	1615	1220	560	315	685	1160	700	3200
			max.										

<sup>2)</sup> Dimension and weight deviations subject to selected motor manufacturer are to be considered

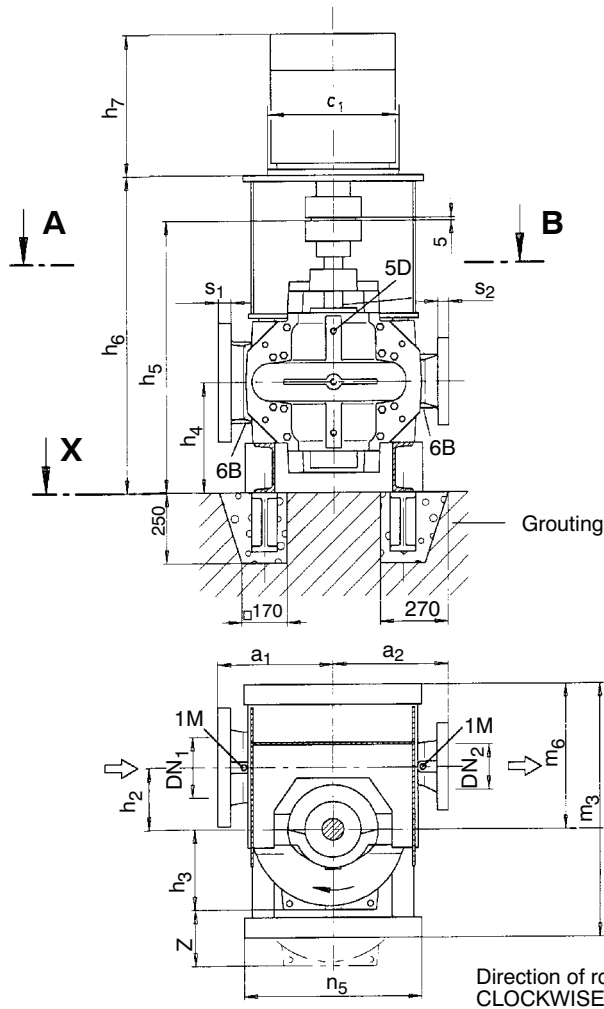
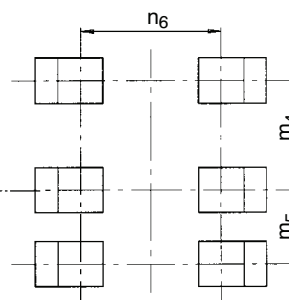
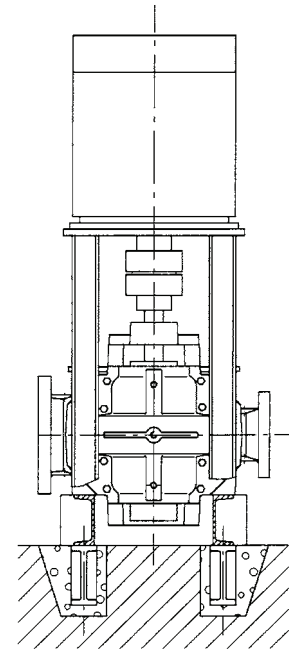
**General arrangement drawing Omega V 250 - 370 up to 250 - 600**
**Type of arrangement DB**

**Section A - B**
**Type of arrangement DK**

**View X**

 Direction of rotation:  
CLOCKWISE

Permissible deviations for:

- Centreline heights DIN 747
- Dimensions without indication of tolerances DIN 7168, medium
- Cast iron parts DIN 1686 GTB 18

Connections:

- 1M Pressure gauge G 1/2
- 5D Vent G 1/2
- 6B Drainage G 1/2
- 8B Leakage liquid drain G 3/4

Flanges:

- Flat surface flanges
- Flange thickness to ANSI
- Connect pipes without stress

Position of the terminal box to be in accordance with motor dimension sheet

**Major external pump dimensions and weights**

all dimensions in mm

Pump size	Flange dimensions				Pump dimensions							Weights [kg]	
	DN <sub>1</sub>	DN <sub>2</sub>	s <sub>1</sub>	s <sub>2</sub>	a <sub>1</sub> <sup>3)</sup>	a <sub>2</sub> <sup>3)</sup>	h <sub>2</sub>	h <sub>3</sub>	h <sub>4</sub>	h <sub>5</sub>	z <sup>2)</sup>	Pump	Water content
250-370	300	250	33 (51) <sup>1)</sup>	32 (48) <sup>1)</sup>	500	500	300	320	440	1095	640	665	125
250-480			51	48	550	550		355	710	830	145		
250-600			650	350	415	500	1230	830	1215	180			

<sup>1)</sup> For casing material GGG-NiCrNb 202, JS 1030 1.4517

<sup>2)</sup> z = The dimensions to be maintained around the casing cover for dismantling of the rotor

<sup>3)</sup> material combinations SB and SC: dimensions are 1% larger

**Standard flange design <sup>1)</sup>:**

Pump size	JL 1040 / GGG-NiCrNb 202 Nominal pressure acc. to:			JS 1030 / 1.4517 Nominal pressure acc. to:		
	DIN 2501 ISO 7005/2	BS 4504	ANSI B 16.1	DIN 2501 ISO 7005/2	BS 4504	ANSI B 16.1
250-370	PN 10	Table 10/11	Class 125	PN 25	Table 25/11	Class 250
250-480	PN 16	Table 16/11	Class 250			
250-600	PN 25	Table 25/11	Class 250			

<sup>1)</sup> Other flange designs are available on request

**Flange dimensions - Drilling diagram** all dimensions in mm

Standard		Suction flange DN 300			Discharge flange DN 250		
		d <sub>2</sub>	k	n	d <sub>2</sub>	k	n
ISO 7005/2 DIN 2501	PN 10	23	400	12	23	350	12
ISO 7005/2 DIN 2501	PN 16	28	410		28	355	
ISO 7005/2 DIN 2501	PN 25	31	430	16	31	370	
BS 4504	Table 10/11	23	400	12	23	350	
BS 4504	Table 16/11	28	410		28	355	
BS 4504	Table 25/11	31	430	16	31	370	
ANSI B 16.1	Class 125	28	432	12	28	362	
ANSI B 16.1	Class 250	31	451	16	28	387	

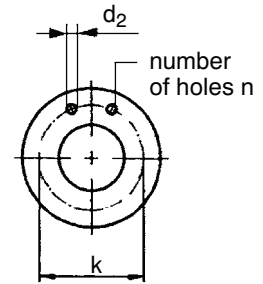
**Motor dimensions and weights IEC-Motors, IP 55 <sup>2)</sup>**

all dimensions in mm

Pump size	Type of arrangement		Motor size	c <sub>1</sub>	h <sub>6</sub>	h <sub>7</sub>	m <sub>3</sub>	m <sub>4</sub>	m <sub>5</sub>	m <sub>6</sub>	n <sub>5</sub>	n <sub>6</sub>	Weight of motor [kg]
	DB	DK											
250-370	•	--	min. 250 M	550	1240	790	1180	560	315	685	900	700	435
			max. 315 L	660	1270	1110							1200
250-480	•	--	min. 250 M	550	1375	790	1210	590	315	715	900	700	435
			max. 355	900	1455	1455							2200
250-600	•	--	min. 315 M	660	1405	970	1210	590	315	715	900	700	910
			max. 355	900	1455	1455							2200
	--	•	min. 400	1000	1445	1615	1350	590	315	715	1260	700	3200
			max. 400	1000	1445	1615	1350						3200

<sup>2)</sup> Dimension and weight deviations subject to selected motor manufacturer are to be considered

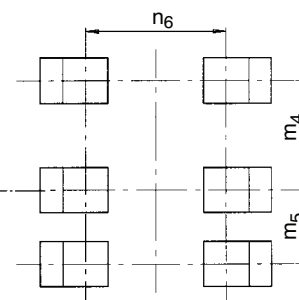
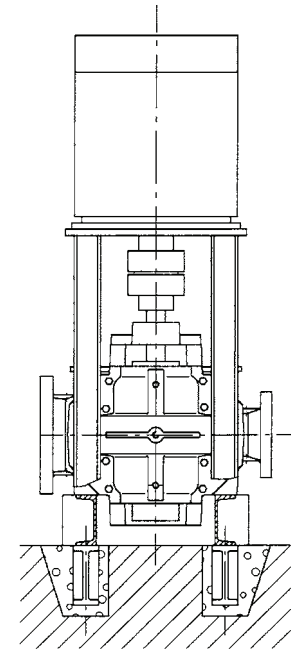
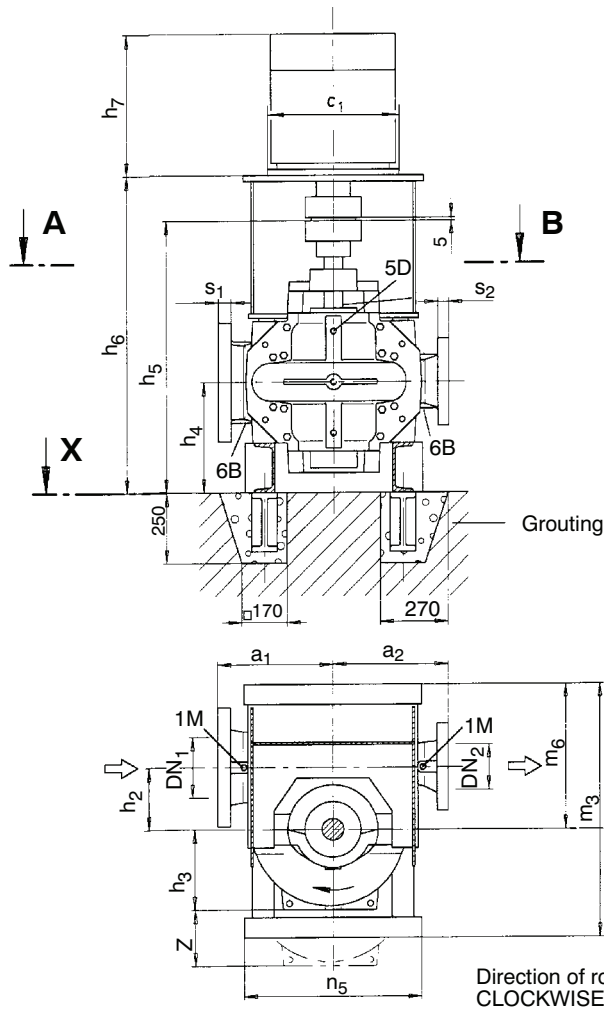
**General arrangement drawing Omega V 300 - 300 up to 300 - 700**
**Type of arrangement DB**
**Type of arrangement DK**

**View X**
**Selection A - B**

Permissible deviations for:

- Centre line heights           DIN 747
- Dimensions without indication  
  of tolerances               DIN 7168, medium
- Cast iron parts               DIN 1686 GTB 18

Connections:

- 1M   Pressure gauge       G 1/2
- 5D   Vent                 G 1/2
- 6B   Drainage             G 1/2
- 8B   Leakage liquid drain G 3/4

Flanges:

- Flat surface flanges
- Flange thickness to ANSI
- Connect pipes without stress

Position of the terminal box to be in accordance with motor dimension sheet

**Major external pump dimensions and weights**

all dimensions in mm

Pump size	Flange dimensions				Pump dimensions							Weights [kg]	
	DN <sub>1</sub>	DN <sub>2</sub>	s <sub>1</sub>	s <sub>2</sub>	a <sub>1</sub> <sup>3)</sup>	a <sub>2</sub> <sup>3)</sup>	h <sub>2</sub>	h <sub>3</sub>	h <sub>4</sub>	h <sub>5</sub>	z <sup>2)</sup>	Pump	Water content
300-300	350	300	36 (54) <sup>1)</sup>	33 (51) <sup>1)</sup>	550	500	300	360	440	1095	720	630	100
300-435	400		38 (57) <sup>1)</sup>		650	550	350	365	500	1230	730	905	190
300-560			57	51	700	650		430	570	1380	860	1425	225
300-700	750		480	570	1380	960	1690	275					

<sup>1)</sup> For casing material GGG-NiCrNb 202, JS 1030 1.4517

<sup>2)</sup> z = the dimensions to be maintained around the casing cover for dismantling of the rotor

<sup>3)</sup> material combinations SB and SC: dimensions are 1% larger

**Standard flange design <sup>1)</sup>:**

Pump size	JL 1040 / GGG-NiCrNb 202 Nominal pressure acc. to:			JS 1030 / 1.4517 Nominal pressure acc. to:		
	DIN 2501 ISO 7005/2	BS 4504	ANSI B 16.1	DIN 2501 ISO 7005/2	BS 4504	ANSI B 16.1
300-300	PN 10	Table 10/11	Class 125	PN 25	Table 25/11	Class 250
300-435						
300-560	PN 16	Table 16/11	Class 250			
300-700	PN 25	Table 25/11				

<sup>1)</sup> Other flange designs are available on request

**Flange dimensions - Drilling diagram**

all dimensions in mm

Standard		Suction flange						Discharge flange		
		DN 350			DN 400			DN 300		
		d <sub>2</sub>	k	n	d <sub>2</sub>	k	n	d <sub>2</sub>	k	n
ISO 7005/2 DIN 2501	PN 10	23	460	16	28	515	16	23	400	12
ISO 7005/2 DIN 2501	PN 16	28	470		31	525		28	410	
ISO 7005/2 DIN 2501	PN 25	34	490		37	550		31	430	16
BS 4504	Table 10/11	23	460		28	515		23	400	12
BS 4504	Table 16/11	28	470		31	525		28	410	
BS 4504	Table 25/11	34	490		37	550		31	430	16
ANSI B 16.1	Class 125	28	476	12	28	540	28	432	12	
ANSI B 16.1	Class 250	31	514	20	34	572	20	31	451	16

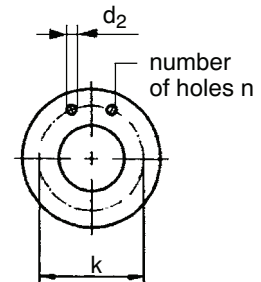
**Motor Dimensions and weights IEC-Motors, IP 55 <sup>2)</sup>**

all dimensions in mm

Pump size	Type of arrangement		Motor size	c <sub>1</sub>	h <sub>6</sub>	h <sub>7</sub>	m <sub>3</sub>	m <sub>4</sub>	m <sub>5</sub>	m <sub>6</sub>	n <sub>5</sub>	n <sub>6</sub>	Weight of motor [kg]
	DB	DK											
300-300	•	--	min. 200 L	400	1210	665	1210	590	315	715	900	700	170
			max. 315 S	660	1270	970							830
300-435	•	--	min. 280 M	550	1375	865	1250	630	400	755	1200	950	660
			max. 315	800	1405	1230							1500
300-560	•	--	min. 315 M	660	1555	970	1375	670	400	795	1200	950	910
			max. 400	1000	1595	1730							3200
300-700	•	--	min. 315	800	1555	1230	1415	710	400	835	1200	950	1500
			max. 400	1000	1615	1615							3200

<sup>2)</sup> Dimension and weight deviations subject to selected motor manufacturer are to be considered

General arrangement drawing Omega V 350 - 360 up to 350 - 510

Type of arrangement DB

Type of arrangement DK

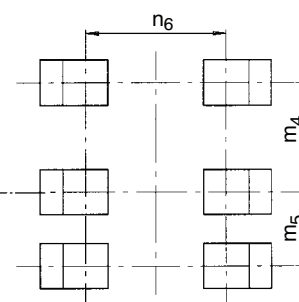
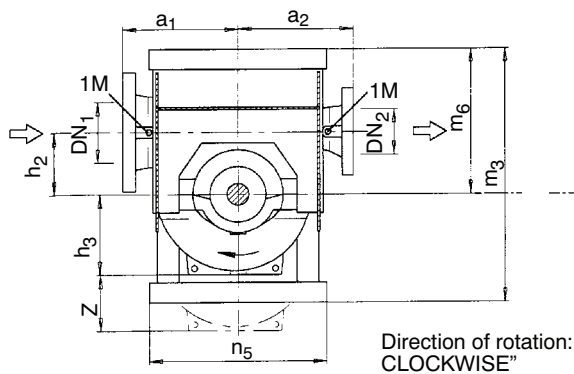
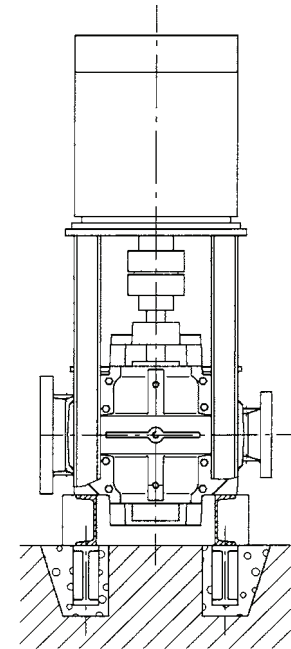
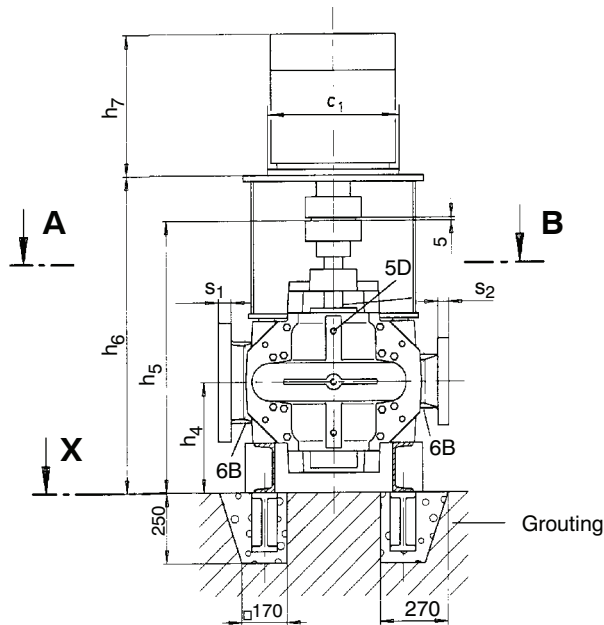

View X

Selection A - B

Permissible deviations for:

- Centreline heights           DIN 747
- Dimensions without indication  
  of tolerances               DIN 7168, medium
- Cast iron parts               DIN 1686 GTB 18

Connections:

- 1M   Pressure gauge       G 1/2
- 5D   Vent                 G 1/2
- 6B   Drainage             G 1/2
- 8B   Leakage liquid drain G 3/4

Flanges:

- Flat surface flanges
- Flange thickness to ANSI
- Connect pipes without stress

Position of the terminal box to be in accordance with motor dimension sheet

Major external pump dimensions and weights

all dimensions in mm

Pump size	Flange dimensions				Pump dimensions							Weights [kg]	
	DN <sub>1</sub>	DN <sub>2</sub>	s <sub>1</sub>	s <sub>2</sub>	a <sub>1</sub> <sup>3)</sup>	a <sub>2</sub> <sup>3)</sup>	h <sub>2</sub>	h <sub>3</sub>	h <sub>4</sub>	h <sub>5</sub>	z <sup>2)</sup>	Pump	Water content
350-360	400	350	38 (57) <sup>1)</sup>	36 (54) <sup>1)</sup>	650	550	350	410	500	1230	820	865	160
350-430	450		41 (60) <sup>1)</sup>		750		465		930	1285	240		
350-510	400		38 (57) <sup>1)</sup>		700	650	400	420	570	1380	840	1395	290

<sup>1)</sup> For casing material GGG-NiCrNb 202, JS 1030 1.4517

<sup>2)</sup> z = The dimensions to be maintained around the casing cover for dismantling of the rotor

<sup>3)</sup> material combinations SB and SC: dimensions are 1% larger

**Standard flange design <sup>1)</sup>:**

Pump size	JL 1040 / GGG-NiCrNb 202 Nominal pressure acc. to:			JS 1030 / 1.4517 Nominal pressure acc. to:		
	DIN 2501 ISO 7005/2	BS 4504	ANSI B 16.1	DIN 2501 ISO 7005/2	BS 4504	ANSI B 16.1
350-360	PN 10	Table 10/11	Class 125	PN 25	Table 25/11	Class 250
350-430				PN 16		
350-510				PN 25		

<sup>1)</sup> Other flange designs are available on request

**Flange dimensions - Drilling diagram**

all dimensions in mm

Standard		Suction flange						Discharge flange		
		DN 400			DN 450			DN 350		
		d <sub>2</sub>	k	n	d <sub>2</sub>	k	n	d <sub>2</sub>	k	n
ISO 7005/2 DIN 2501	PN 10	28	515	16	28	565	20	23	460	16
ISO 7005/2 DIN 2501	PN 16	31	525		31	585		28	470	
BS 4504	Table 10/11	28	515		28	565		23	460	
BS 4504	Table 16/11	31	525		31	585		28	470	
ANSI B 16.1	Class 125	28	540					16	28	

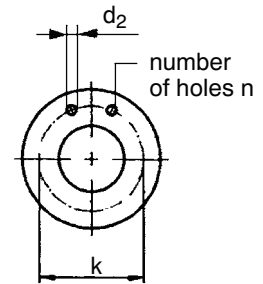
**Motor dimensions and weights IEC-Motors, IP 55 <sup>2)</sup>**

all dimensions in mm

Pump size	Type of arrangement		Motor size	c <sub>1</sub>	h <sub>6</sub>	h <sub>7</sub>	m <sub>3</sub>	m <sub>4</sub>	m <sub>5</sub>	m <sub>6</sub>	n <sub>5</sub>	n <sub>6</sub>	Weight of motor [kg]
	DB	DK											
350-360	•	--	min. 250 M	550	1375	790	1250	630	315	755	900	700	435
			max. 315	800	1405	1230							1500
350-430	•	--	min. 315 M	660	1555	940	1415	710	400	835	1200	950	910
			max. 355	900	1555	1455							2200
350-510	•	--	min. 315 L	660	1555	1110	1415	710	400	835	1200	950	1200
			max. 400	1000	1595	1615							3200

<sup>2)</sup> Dimension and weight deviations subject to selected motor manufacturer are to be considered

## Spare parts

1. Recommended for spare parts for **commissioning**
2. Recommended for spare parts for **2-years operation** (8000 hours per year)
3. Recommended for spare parts for **5-years operation** (8000 hours per year)

### 1. Proposals for spare parts for **commissioning**

Part no.	Part designation	Number of pumps including stand-by pumps							
		1	2	3	4	5	6	8	10 and more
		Number of spare parts							
321 550.1/2 520	Set Deep groove ball bearings Washers Sleeve	1	1	1	2	2	3	4	5
411.1 412.1-6 421.1/2	Set V-Rings O-Rings Radial shaft seal ring	1	2	3	4	5	6	8	10

### for the mechanical seal-fitted pump

Part no.	Part designation	Number of pumps including stand-by pumps							
		1	2	3	4	5	6	8	10 and more
		Number of spare parts							
433	Set Mechanical seals	1	1	1	2	2	3	4	5

### for the gland-fitted pump

Part no.	Part designation	Number of pumps including stand-by pumps							
		1	2	3	4	5	6	8	10 and more
		Number of spare parts							
461	Gland packing (Set packing rings)	1	2	3	4	5	6	8	10

## Spare parts

2. Recommended for spare parts for **2-years operation** (8000 hours per year)

Part no.	Part designation	Number of pumps including stand-by pumps								E = spare part R = replacement part V = wear part
		1	2	3	4	5	6	8	10 and more	
		Number of spare parts								
211 920.3 932 940.1/2/3	Shaft, with Nut Circlip Keys	-	-	-	1	1	1	2	3	E
524.1	Set shaft protec. sleeve	1	1	1	2	2	3	4	5	V
234	Impeller	-	-	-	1	1	1	2	3	E
502	Set of casing wear rings	1	1	1	2	2	3	4	5	V
503	Set of impeller wear rings (if mounted)	1	1	1	2	2	3	4	5	V
321 550.1/2 520	Set consisting of Deep groove ball bearings Washers Sleeve	1	1	1	2	2	3	4	5	R
411.1 412.1-6 421.1/2	Set consisting of V-Rings O-Rings Radial shaft seal rings	1	2	3	4	5	6	8	10	V

### for the mechanical seal-fitted pump

Part no.	Part designation	Number of pumps including stand-by pumps								E = spare part R = replacement part V = wear part
		1	2	3	4	5	6	8	10 and more	
		Number of spare parts								
433	Set of Mechanical seals	1	1	1	2	2	3	4	5	V

### for the gland-fitted pump

Part no.	Part designation	Number of pumps including stand-by pumps								E = spare part R = replacement part V = wear part
		1	2	3	4	5	6	8	10 and more	
		Number of spare parts								
452 455 457 458	Set consisting of Gland Stuffing box insert Neck rings Lantern rings	-	-	-	1	1	1	2	3	R
461	Gland packing (Set packing rings)	4	8	12	16	20	24	32	40	V

### for the vertical design

Part no.	Part designation	Number of pumps including stand-by pumps								E = spare part R = replacement part V = wear part
		1	2	3	4	5	6	8	10 and more	
		Number of spare parts								
524.2 545 350.2	Residur bearing, compl. Shaft protec. sleeve Bearing bush Bearing housing	1	1	1	2	2	3	4	5	V

**Spare parts**

 3. Recommended for spare parts for **5-years operation** (8000 hours per year)

Part no.	Part designation	Number of pumps including stand-by pumps								E = spare part R = replacement part V = wear part
		1	2	3	4	5	6	8	10 and more	
		Number of spare parts								
211 920.3 932 940.1/2/3	Shaft, with Nut Circlip Keys	1	1	1	2	2	2	4	6	E
524.1	Set shaft protec. sleeve	2	2	2	4	4	6	8	10	V
234	Impeller	1	1	1	2	2	2	4	6	E
502	Set of casing wear rings	2	2	2	4	4	6	8	10	V
503	Set of impeller wear rings (if mounted)	2	2	2	4	4	6	8	10	V
321 550.1/2 520	Set consisting of Deep groove ball bearings Washers Sleeve	2	2	2	4	4	6	8	10	R
411.1 412.1-6 421.1/2	Set consisting of V-Rings O-Rings Radial shaft seal rings	2	2	6	8	8	12	16	20	V

**for the mechanical seal-fitted pump**

Part no.	Part designation	Number of pumps including stand-by pumps								E = spare part R = replacement part V = wear part
		1	2	3	4	5	6	8	10 and more	
		Number of spare parts								
433	Set of Mechanical seals	2	2	2	4	4	6	8	10	V

**for the gland-fitted pump**

Part no.	Part designation	Number of pumps including stand-by pumps								E = spare part R = replacement part V = wear part
		1	2	3	4	5	6	8	10 and more	
		Number of spare parts								
452 455 457 458	Set consisting of Gland Stuffing box insert Neck rings Lantern rings	1	1	1	2	2	2	4	6	R
461	Gland packing (Set packing rings)	10	20	30	40	50	60	80	100	V

**for the vertical design**

Part no.	Part designation	Number of pumps including stand-by pumps								E = spare part R = replacement part V = wear part
		1	2	3	4	5	6	8	10 and more	
		Number of spare parts								
524.2 545 350.2	Residur bearing, compl. Shaft protec. sleeve Bearing bush Bearing housing	2	2	2	4	4	6	8	10	V

**Motor dimensions and weights ( Type of arrangement 3E )**

IEC-Motors; IP 55; IM B 3 configuration

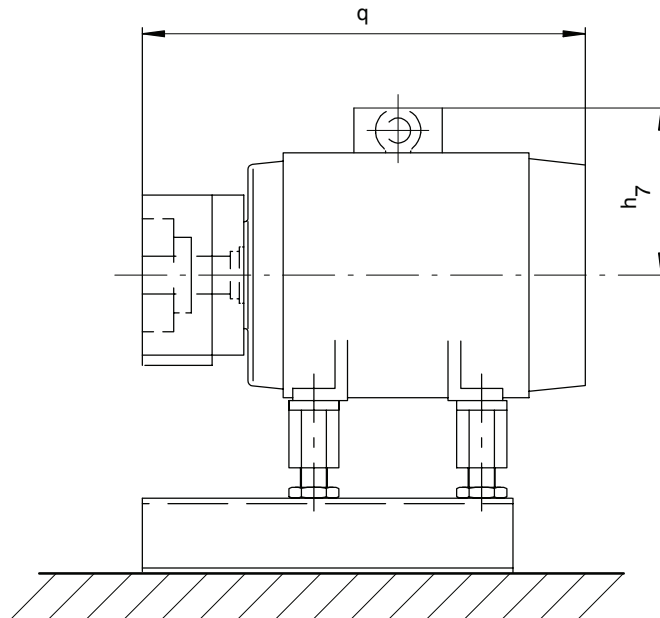
**Motor dimensions and weights**

all dimensions in mm

Motor size		q		h <sub>7</sub>		Motor weight [kg]	
2 pole	4 pole	2 pole	4 pole	2 pole	4 pole	2 pole	4 pole
	100 L		373		135		24
	112 M		394		150		31
	132 S		454		170		45
	132 M						56
160 M	160 M	588	588	200	200	85	76
160 L	160 L					102	93
180 M	180 M	712	712	260	260	115	112
--	180 L						126
200 L	200 L	770	770	310	310	188	170
--	225 S		807		310		215
225 M	225 M	777				310	310
250 M	250 M	930	930	430	430	415	435
280 S	280 S	1005	1005	455	455	570	610
280 M	280 M					610	660
315 S	315 S	1110	1140	515	515	790	830
315 M	315 M					850	910
315 L	315 L					1250	1280
315	315	1370	1400	520	520	1500	1500
355	355		1625		550		2200
400	400		1825		625		3200

- Weights to KSB standard

- Dimension and weight deviations subject to selected motor manufacturer are to be considered





