

Data sheet

Gear pumps
R25/2.5 to R105/2400

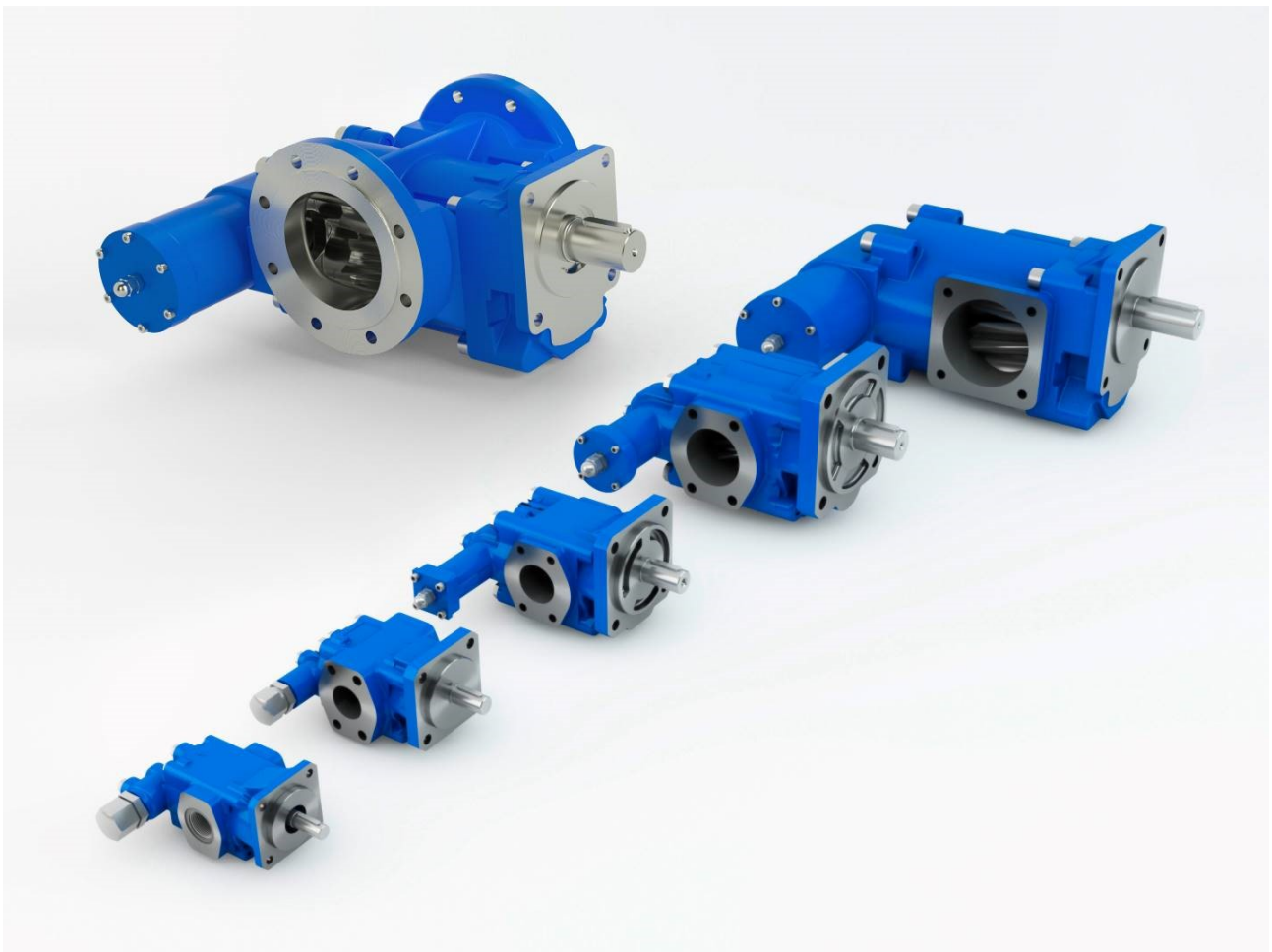

Publisher
RICKMEIER GmbH
Langenholthausener Straße 20-22
D-58802 Balve

Telephone +49 (0) 23 75 / 9 27-0
Telefax +49 (0) 23 75 / 9 27-26
kontakt@rickmeier.de
www.rickmeier.de

© 2019, RICKMEIER GmbH

All rights reserved. Content may not be distributed, copied, edited or shared with third parties without the express written consent of the RICKMEIER GmbH.

An example configuration is shown on the title page. The delivered product may be different than the one shown.

Table of contents

1	General information	5
2	Areas of application	6
3	Description	7
3.1	Design	7
3.2	Product description	7
4	Functioning principle	8
5	Direction of rotation and delivery	9
5.1	Determining the direction of rotation	9
5.2	Changing the direction of rotation and conveyance	9
6	Guidelines and acceptance	9
7	Standard design and variants	10
7.1	Materials	10
7.2	Mounting flange	11
7.3	Connections	12
7.4	Shaft end	13
7.5	Shaft seal	14
7.5.1	Radial shaft seal (RWDR)	14
7.5.2	Mechanical seal (GLRD)	15
7.6	Pressure relief valve (DB)	15
7.7	Reversing valve (UNI function)	16
7.8	Attachment bearing	17
7.9	Double pump	17
7.10	Integrated heating	17
7.11	Noise optimisation	18
8	Designation and configuration	18
8.1	Type key	18
8.2	Pump selection	18
8.2.1	Size (type)/geometric displacement volume V_g	19
8.2.2	Design	19
8.2.3	Shaft end	19
8.2.4	Pressure relief valve	20
8.2.5	Pressure relief valve - pressure range/presetting	20
8.2.6	Shaft seal	20
8.2.7	Connection/connection size	21
8.2.8	Direction of rotation (facing the shaft end)	21
8.2.9	Materials	21
8.2.10	Additional options	22
8.3	Pump design	23
9	Technical data	24
9.1	Operational limits	24
9.2	Operating data	25
10	Dimensional sheets of gear pumps	29
10.1	Size R25	29
10.2	Size R35	30

10.3 Size R45	31
10.4 Size R65	32
10.5 Size R95	33
11 Dimensional sheets of pump units	34
11.1 Size R25	34
11.1.1 Type IM B35	34
11.1.2 Type IM B5 with unit foot	35
11.1.3 Type IM V1/B5	36
11.2 Size R35	37
11.2.1 Type IM B35	37
11.2.2 Type IM B5 with unit foot	38
11.2.3 Type IM V1/B5	39
11.3 Size R45	40
11.3.1 Type IM B35	40
11.3.2 Type IM B5 with unit foot	41
11.3.3 Type IM V1/B5	42
11.4 Size R65	43
11.4.1 Type IM B35	43
11.4.2 Type IM B5 with unit foot	44
11.4.3 Type IM V1/B5	45
11.5 Size R95	46
11.5.1 Type IM B35	46
11.5.2 Type IM B5 with unit foot	47
11.5.3 Type IM V1/B5	48

1 General information

The technical data in this catalogue are intended for general information. During installation, operation and maintenance, the operating instructions and the information specified on the products must be observed.

Changes to the technical data, selection and ordering data, accessories and deliverability are reserved.

All dimensions are in millimetres.

2 Areas of application

RICKMEIER gear pumps are used primarily in oil hydraulics, lubrication technology and for the transport of various oils or lubricating substances.

Typical areas of application		
General machine construction	Automobile manufacturing	Apparatus construction
Construction machines	Mining technology	
Chemical plant construction		
Diesel motors	Printing machines	
Electric motor construction		
Vehicle technology		
Gas turbines	Gearing	Foundry technology
Woodworking technology		
Industrial gear manufacturing		
Refrigeration technology	Compressor construction	Power plant construction
Engine and motor construction		
Paper machines	Pump construction	
Ship construction		
Textile machines		
Compressor construction		
Water turbines	Rolling mill industry	Machine tools
Wind power generation		
Cement factory construction		

Typical flow media	
Waste oil	ATF oil
Drilling oil	
Diesel fuels	
Emulsions	
Gear oil	
Heating oils	Hydraulic oil
Motor oil	
Polyglycol oil	Polyalphaolefin oil
Cutting oil	Heavy oil
Heat transfer oil	
Drawing oil	



Illustration 1: Application examples

3 Description

3.1 Design

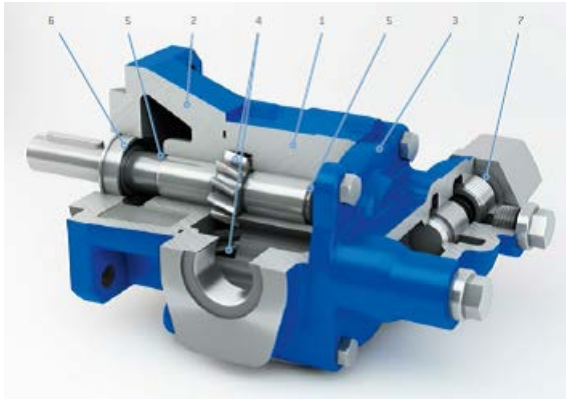

Illustration 2: Gear pump - standard design

1 Gear casing	2 Driving cover
3 End cover	4 Hardened gear shafts
5 Multicomponent friction bearing	6 Radial shaft seal
7 Option: pressure relief valve	

3.2 Product description

RICKMEIER gear pumps are characterised by a simple and robust structure. Short, straight flow channels ensure good priming characteristics and quiet running. Together with a special design of the toothing and the gear casing, an extremely low noise level is ensured during operation.

The casings of the standard version are made of grey cast iron, the gear parts of hardened steel. Generously dimensioned, specially coated multicomponent friction bearings have a long service life and very good dry-running properties.

The shaft seal is designed as standard with a radial shaft seal. In addition, numerous sealing variants are possible (such as a mechanical seal).

4 Functioning principle

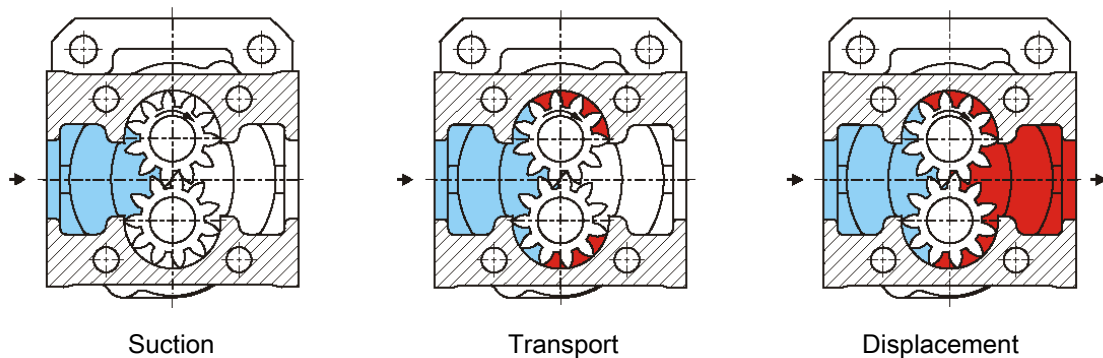

Illustration 3: Gear pump delivery principle

Gear pumps are rotary displacement pumps. When the gear shafts turn, the medium enclosed in the space between the teeth is transported from the suction to the pressure side. Then the medium is displaced toward the pressure side by the intermeshing teeth. The transport of the flow medium results in a pressure drop on the suction side of the gear pump. The flow medium compensates for this pressure drop by flowing in, thereby maintaining the feed process.

This process is the same for both gaseous and liquid media. As a result, the gear pump is capable of priming the suction pipe itself until it is completely filled with liquid flow medium.



Note

The venting of the suction line is not possible under the following conditions:

- The suction line is leaking which means that a vacuum cannot develop.
- The pressure in the suction-side pipeline system and/or tank is too low to allow a subsequent flow of the pumped medium. This is possible if a vacuum is present or if the liquid level is too far below the gear pump.
- On the pressure side of the gear pump, a non-return valve is installed (provide a bleeder valve).

Pressure relief valve

The pressure relief valve integrated in the end cover of the gear pump as an option is designed as a spring-loaded valve. It may only be used as an occasionally actuated valve for pressure relief.



Note

If a larger partial volume of the flow medium must be drained off over an extended period, a separate valve with a return pipe to the suction tank in the pipe (e.g. Rickmeier valves of type RSn, DBV40 or DB9) must be provided.



Illustration 4: Pressure relief valve for pipe installation (example: DB9)

5 Direction of rotation and delivery

5.1 Determining the direction of rotation

Unless otherwise stated, the gear pump rotation is "clockwise" when looking at the face of the driving gear shaft (see the following figure).

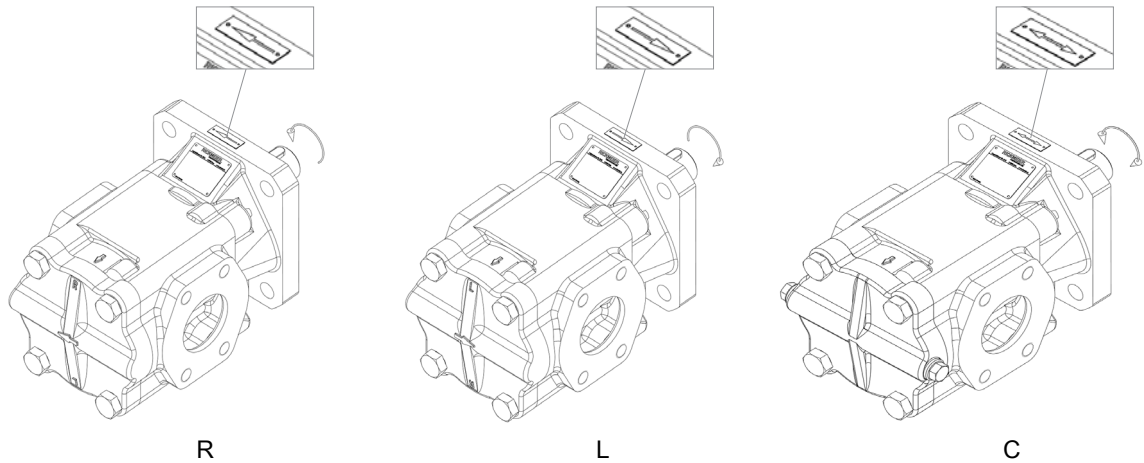

Illustration 5: Direction of rotation and delivery
(Direction of rotation R: clockwise; direction of rotation L: anti-clockwise; direction of rotation C: clockwise and anti-clockwise)



Note

When the optional C version is equipped, the gear pumps can be operated in both clockwise and anti-clockwise rotation (with changing direction of delivery). This version is only possible in the case of gear pumps without a pressure relief valve.

5.2 Changing the direction of rotation and conveyance

Depending on the design and size, it is possible to convert the gear pumps locally to the other direction of rotation (with a changed direction of delivery).
Please contact our customer service (with the data on the name plate).

6 Guidelines and acceptance

RICKMEIER is certified according to EN ISO 9001 and EN ISO 14001.

In addition, RICKMEIER implements the specifications in accordance with the REACH Regulation 1907/2006/EC.

RICKMEIER gear pumps can be supplied in accordance with the ATEX Directive 2014/34/EU. Since the approval depends on the application and design of the gear pump, please contact Sales.

Upon request, all products can be supplied with factory certificate EN 10204-2.2 or acceptance test certificate EN 10204-3.1.

The purchase of gear pumps through classification societies is also possible at our company (e.g., through Lloyd's Register, Bureau Veritas, DNV GL and many others).

7 Standard design and variants

The variable modular system of RICKMEIER gear pumps makes it possible to implement a wide variety of material, casing, sealing and functional variants.

In addition to a standard version, the gear pumps can be adapted to the respective application due to the diverse and variable possibilities.

7.1 Materials

	Standard	Alternative
Casing	– EN-GJL-250 (GG-25)	– EN-GJS-400-15 (GGG-40)
Gear shafts	– Case-hardened steel (16MnCrS5)	
Radial shaft seals	– NBR – FKM	– HNBR – PTFE – EPDM – Additional upon request
Mechanical seals	– Hard carbon/SiC	– Various material combinations upon request
O-rings	– NBR – FKM	– HNBR – PTFE – EPDM – Additional upon request
Friction bearing	– Composite bearing type P10/DU	– Friction bearings free of ferrous and non-ferrous metals – Additional upon request
Corrosion protection	– 2-component paint, RAL 6011	– Various coating materials and structures available upon request, for example: C4

Table 1: Materials

7.2 Mounting flange

In the standard version, the gear pumps have a square mounting flange.

On request, the standard mounting flanges can be provided with a bolt-on angled pump foot ("FU" design).

Alternatively, it is possible to design the mounting flange as a custom solution in any shape, such as round or oval.





Standard	<i>Alternative (customer-specific solutions in any form)</i>
<p data-bbox="296 488 383 526">Square</p>  <p data-bbox="296 860 475 896">Example: R25</p>	<p data-bbox="798 488 877 526">Oval</p>  <p data-bbox="798 860 1066 896">Example: R25</p>
<p data-bbox="296 896 798 963">Additional bolt-on angled pump foot ("FU" design)</p>  <p data-bbox="296 1296 475 1332">Example: R35</p>	<p data-bbox="798 896 877 931">Round</p>  <p data-bbox="798 1296 1066 1332">Example: R35</p>  <p data-bbox="798 1621 1066 1657">Example: R65</p>  <p data-bbox="798 1946 1066 1982">Example: R95</p>

Table 2: Mounting flange design variants

7.3 Connections

Depending on the size, the pipe connections are designed as follows:

R25	Threaded hole with inch thread or metric SAE flange pattern according to ISO 6162
R35 through R65	Metric SAE flange pattern according to ISO 6162
R95	Flange pattern according to Rickmeier standard
R105	Flange pattern according to EN 1092-1

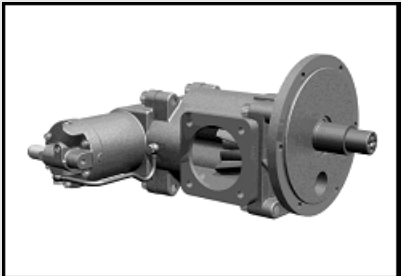
Depending on customer requirements, alternatively special gear casings with any connection diagram can be supplied, such as axial pipe connections, plug-in pipe connections or flange patterns according to SOLAS (in combination with standard pump components).





Standard	Alternative (customer-specific solutions in any form) or flange patterns according to SOLAS
<p>Threaded hole with inch thread</p>  <p>Example: R25</p>	<p><i>Axial</i></p>  <p>Example: R25</p>
<p>Metric SAE flange pattern according to ISO 6162</p>  <p>Example: R35</p>	<p><i>Flange pattern offset to middle of axis</i></p>  <p>Example: R65</p>
<p>Flange pattern according to Rickmeier standard (Size R95)</p>  <p>Example: R95</p>	
<p>Flange pattern according to EN 1092-1 (Size R105 – upon request)</p>	

Table 3: Pipe connection design variants

7.4 Shaft end

In the standard design, the gear pumps have a cylindrical shaft end and fitted key.

The shaft version with tapered seat 1:10 is available in many sizes (e.g., for the positive connection of a pinion). In addition, shaft ends of different designs are possible, for example, cylindrical without fitted key or cylindrical with internal thread, with splined shaft DIN 5480 or with tappet (Oldham coupling).





Standard	Alternative
<p>Cylindrical, with fitted key</p>  <p>Example: R25</p>	<p>Conical seat 1:10</p>  <p>Example: R25</p>
	<p>Toothed shaft profile according to DIN 5480</p>  <p>Example: R35</p>
	<p>Tappet (Oldham coupling)</p>  <p>Example: R35</p>

Table 4: Shaft end design variants

7.5 Shaft seal

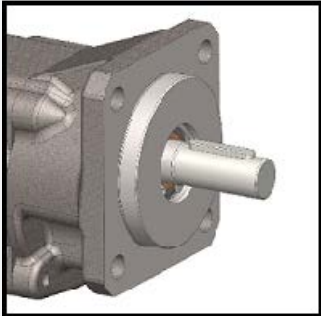
7.5.1 Radial shaft seal (RWDR)

For many use cases, the standard built-in radial shaft seal is the best economical and technical solution. It is a wear-optimized design that ensures a long service life.

In addition, the following seal variants are available for special requirements in various material combinations (see Table 5):

- Without radial shaft seal (direct attachment of the gear pump to the gearing or motor casing)
- Single radial shaft seal with increased inlet pressure at the pump inlet (up to 6 bar)
- Double radial shaft seal with connection hole for liquid reservoir
- Double radial shaft seal for vacuum operation with connection hole for liquid reservoir
- Double radial shaft seal for media separation (with leakage control hole)

A screw-in oil reservoir for liquid feed can be supplied on request.

Standard	Alternative
<p data-bbox="268 763 544 790">Simple radial shaft seal</p> 	<p data-bbox="858 763 1145 790">Without radial shaft seal</p> 
	<p data-bbox="858 1137 1433 1196">Double radial shaft seal with connection hole for liquid reservoir</p> 
	<p data-bbox="858 1547 1393 1606">Double radial shaft seal for media separation (with leakage control hole)</p> 

Table 5: Sealing with radial shaft seal design variant

7.5.2 Mechanical seal (GLRD)

All gear pumps can be equipped as a special design with mechanical seals. The suitable design and material combination will be selected according to application and flow medium.

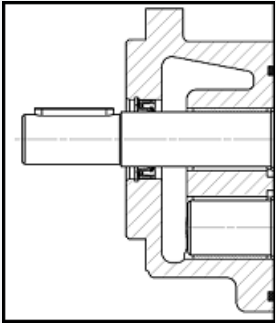
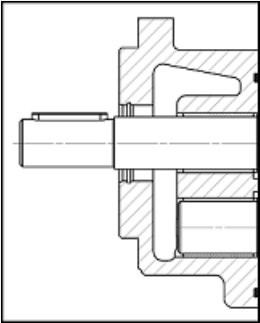
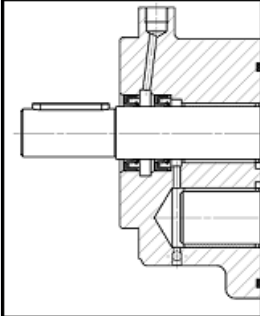
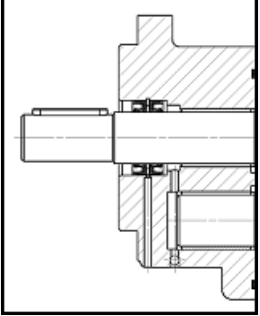
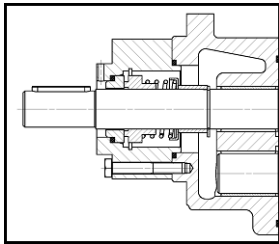
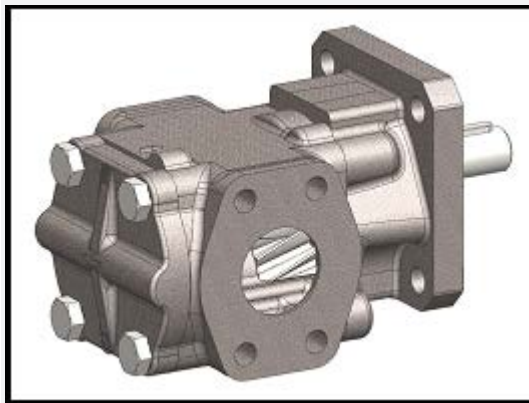

Illustration 6: Mechanical seal

7.6 Pressure relief valve (DB)

All gear pumps of the R5 series can alternatively be supplied with or without pressure relief valve (DB).

Without DB



Example: R35

With DB

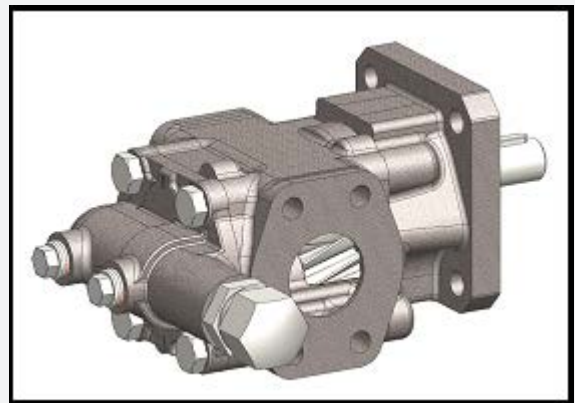

Example: R35

Table 6: Design variants for gear pump with or without pressure relief valve

The pressure relief valve integrated into the end cover of the gear pump is a spring-loaded valve. Since the discarded oil circulates internally, it may only be used as an occasionally actuated valve for pressure relief.

We can offer the following variants for the design of the pressure relief valve:

- With a damped piston
- In heat-resistant design for operating temperatures > 80°C
- As a pressure control valve with external actuation

Standard

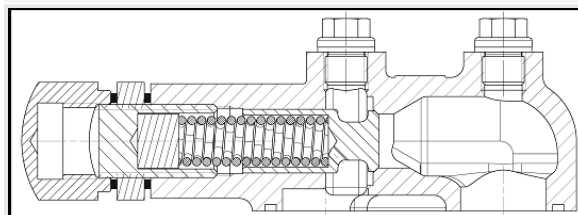

Example: R35

Alternative

– With a damped piston

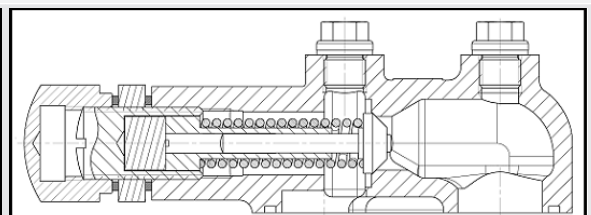

Example: R35

Table 7: Pressure relief valve (DB) design variants

7.7 Reversing valve (UNI function)

By means of a flange-mounted reversing valve, it is possible to operate the gear pump with alternating direction of rotation without changing the flow direction. Available for sizes R35 to R65.

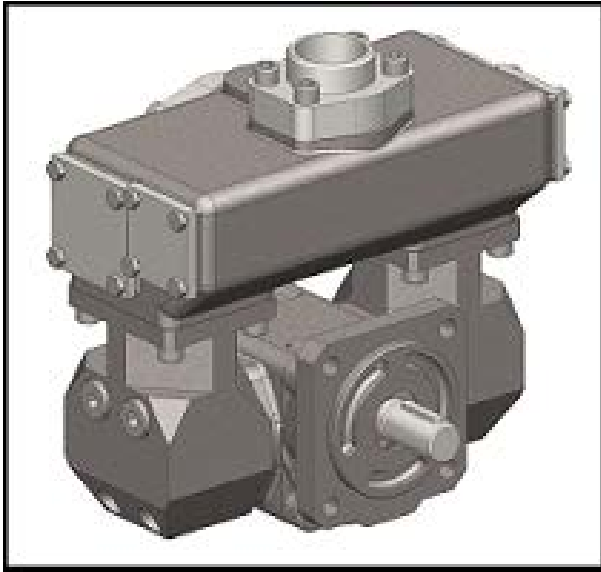

Illustration 7: Gear pump with reversing valve (example: R45)



Note

As an alternative to the R5 series with a reversing valve, our compact UNI pump can be used up to a displacement volume of 160 cm³. The maintenance of the direction of flow when the direction of rotation is reversed is realized by a special design without switching valves. This gear pump is therefore particularly suitable when low pressure losses are required (e.g., at low temperatures and/or high viscosities).

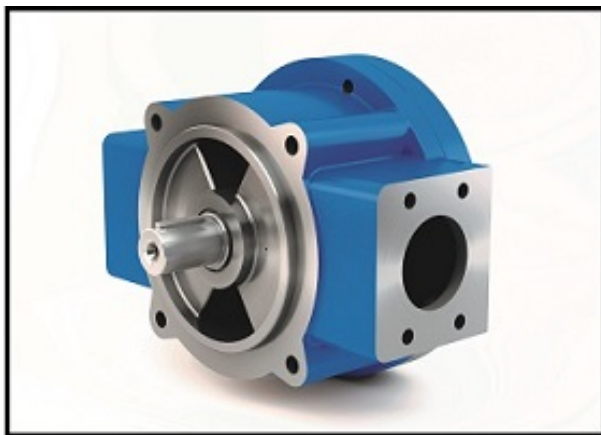

Illustration 8: UNI pump (example: R6.0)

7.8 Attachment bearing

Optional, e.g. at increased radial load on the shaft journal or pinion drive, an additional bearing can be provided in the driving cover. In addition, separate attachment bearing units can be designed for special applications.

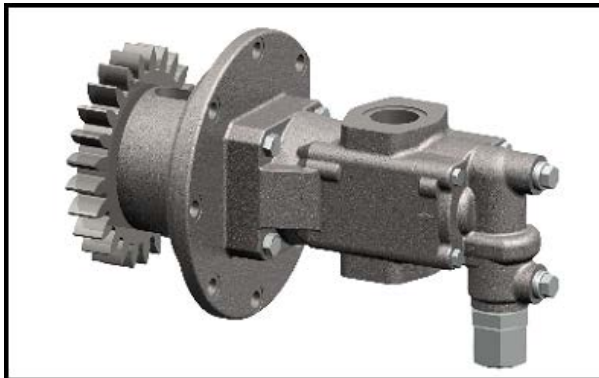

Illustration 9: Gear pump with attachment bearing unit (example: R25)

7.9 Double pump

Gear pumps of sizes R25 to R45 can be combined to double pumps. The two stages can be executed with or without sealing to each other.

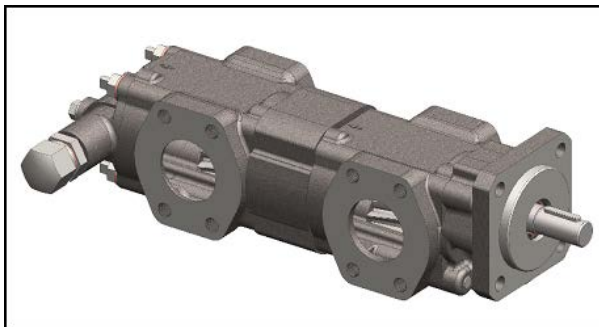

Illustration 10: Double pump with pressure relief valve (example: R35)

7.10 Integrated heating

When operating R35 and R45 gear pumps in cold climates, a "cold climate" version (CCV) (down to -40°C) with integrated heater is available to reduce wear, drive power and starting current.

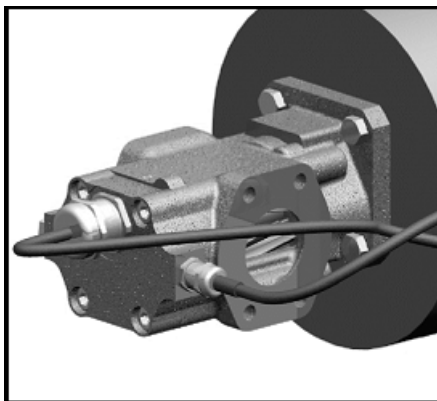

Illustration 11: Gear pump with integrated heating in end cover (example: R35)

7.11 Noise optimisation

In applications with flow media with increased air content, a significant noise pollution by the gear pump is often determined. Pump casings of all sizes can be optionally equipped with an internal additional machining, which in this case causes a significant reduction of the sound pressure level.

Depending on operating data and air content, sound pressure level reductions up to 15 dB(A) are possible. The delivery performance and efficiency of the gear pump are not adversely affected by this, but no noise reduction is to be expected due to this modification in the case of flow medium that do not contain air.

8 Designation and configuration

8.1 Type key

The designation of the RICKMEIER gear pumps is made according to the following key:

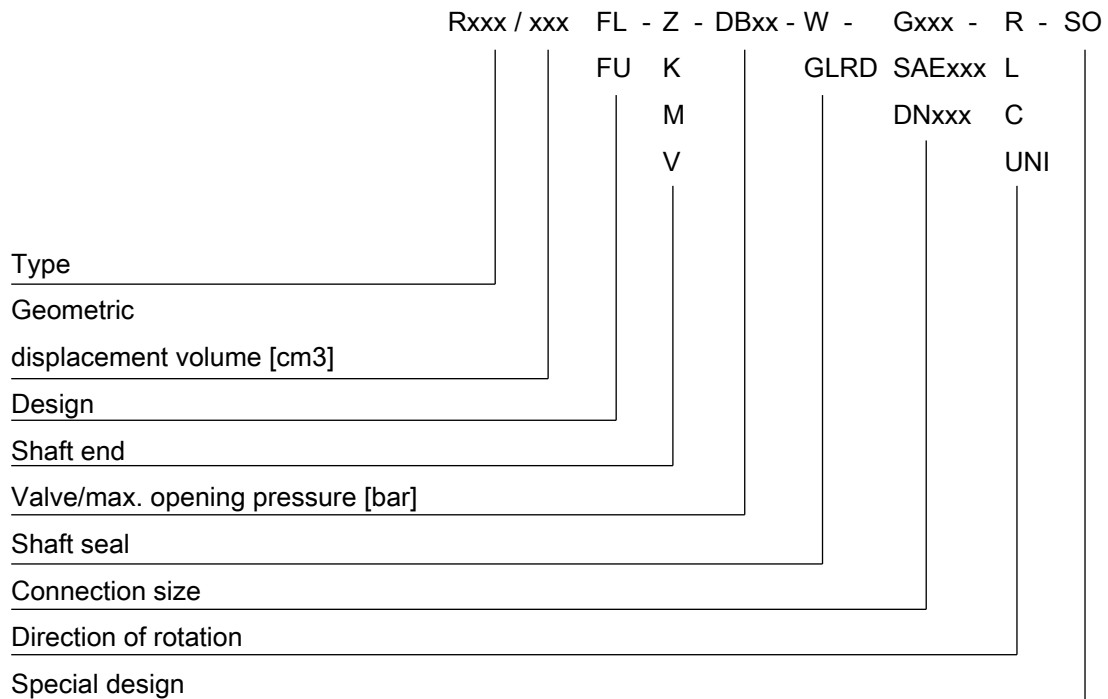

Illustration 12: Type key

8.2 Pump selection

The following selection tables allow you to configure the desired pump design by ticking options. The completed sheets can be sent to us together with your request.

For many applications, the **bolded** standard versions are sufficient. For further information on the *italicised* options and variants, please contact us.

The gear pumps can naturally also be designed with our support. In that case, please contact us; please use the table in the following chapter "Pump design."

8.2.1 Size (type)/geometric displacement volume V_g

<input type="checkbox"/> R25	<input type="checkbox"/> 2.5	<input type="checkbox"/> 3.15	<input type="checkbox"/> 4	<input type="checkbox"/> 5	<input type="checkbox"/> 6.3
	<input type="checkbox"/> 8	<input type="checkbox"/> 10	<input type="checkbox"/> 12.5	<input type="checkbox"/> 16	<input type="checkbox"/> 20
<input type="checkbox"/> R35	<input type="checkbox"/> 25	<input type="checkbox"/> 31.5	<input type="checkbox"/> 40		
	<input type="checkbox"/> 50	<input type="checkbox"/> 63	<input type="checkbox"/> 80		
<input type="checkbox"/> R45	<input type="checkbox"/> 80	<input type="checkbox"/> 100	<input type="checkbox"/> 112	<input type="checkbox"/> 125	
	<input type="checkbox"/> 160	<input type="checkbox"/> 180	<input type="checkbox"/> 200		
<input type="checkbox"/> R65	<input type="checkbox"/> 200	<input type="checkbox"/> 250	<input type="checkbox"/> 315		
	<input type="checkbox"/> 400	<input type="checkbox"/> 500	<input type="checkbox"/> 630		
<input type="checkbox"/> R95	<input type="checkbox"/> 710	<input type="checkbox"/> 800	<input type="checkbox"/> 900	<input type="checkbox"/> 1000	
	<input type="checkbox"/> 1120	<input type="checkbox"/> 1250	<input type="checkbox"/> 1400	<input type="checkbox"/> 1600	
<input type="checkbox"/> R105	<input type="checkbox"/> 1800	<input type="checkbox"/> 2000	<input type="checkbox"/> 2200	<input type="checkbox"/> 2400	

→ Please select a displacement volume V_g [cm³] and the corresponding size!

8.2.2 Design

<input type="checkbox"/> FL	Square mounting flange
<input type="checkbox"/> FU	<i>With bolted-on foot</i>
<input type="checkbox"/> OTHER	<i>E.g., round, oval</i>

→ Please select a design! For designs other than "FL", please contact us.

8.2.3 Shaft end

<input type="checkbox"/> Z	Cylindrical shaft end with fitted key
<input type="checkbox"/> K	<i>Tapered shaft end</i>
<input type="checkbox"/> M	<i>Tappet</i>
<input type="checkbox"/> V	<i>Gearing</i>
<input type="checkbox"/> OTHER	<i>E.g., cylindrical shaft end with fitted key</i>

→ Please select a shaft end! If the shaft end differs from "Z", please contact us.

8.2.4 Pressure relief valve

<input type="checkbox"/> Without DB	Without pressure relief valve
<input type="checkbox"/> With DB	With pressure relief valve
	<input type="checkbox"/> <i>Optional: damped design</i>
	<input type="checkbox"/> <i>Optional: heat-resistant design (for media temperatures > 80°C)</i>
	<input type="checkbox"/> <i>Optional: pilot-operated version (possible with size R65/R95/R105)</i>

→ Please select whether the gear pump should be equipped with or without an integrated pressure relief valve (DB)! If "With DB" is selected, please select optional versions (if desired).

8.2.5 Pressure relief valve - pressure range/presetting

R25	<input type="checkbox"/> DB4 (1...4 bar)	<input type="checkbox"/> DB16 (4...16 bar)	<input type="checkbox"/> DB25 (16...25 bar)
R35	<input type="checkbox"/> DB6 (1...6 bar)	<input type="checkbox"/> DB16 (6...16 bar)	<input type="checkbox"/> DB25 (16...25 bar)
R45	<input type="checkbox"/> DB4 (1...4 bar)	<input type="checkbox"/> DB16 (4...16 bar)	<input type="checkbox"/> DB25 (16...25 bar)
R65	<input type="checkbox"/> DB4 (1...4 bar)	<input type="checkbox"/> DB16 (4...16 bar)	<input type="checkbox"/> DB25 (16...25 bar)
R95	<input type="checkbox"/> DB7 (1...7 bar)	<input type="checkbox"/> DB12 (7...12 bar)	
R105	<input type="checkbox"/> DB7 (1...7 bar)	<input type="checkbox"/> DB12 (7...12 bar)	
Presetting	bar		
Opening pressure:			

→ For the version "With DB" please select a pressure range for the preselected size!

→ Please enter the desired presetting for the opening pressure; otherwise the opening pressure is preset to the maximum pressure.

8.2.6 Shaft seal

<input type="checkbox"/> Without	Without
<input type="checkbox"/> W	<input type="checkbox"/> Simple radial shaft seal (RWDR), wear-optimised
	<input type="checkbox"/> <i>Variant: single radial shaft seal with increased inlet pressure at the pump inlet (up to 6 bar)</i>
	<input type="checkbox"/> <i>Variant: double radial shaft seal with connection hole for liquid reservoir</i>
	<input type="checkbox"/> <i>Variant: double radial shaft seal for vacuum operation with connection hole for liquid reservoir</i>
	<input type="checkbox"/> <i>Variant: double radial shaft seal for media separation (with leakage control hole)</i>
<input type="checkbox"/> GLRD	<input type="checkbox"/> Mechanical seal with inlet pressure at the pump inlet up to 10 bar
	<input type="checkbox"/> <i>Variant: mechanical seal for inlet pressure at pump inlet > 10 bar</i>

→ Please select a shaft seal! When selecting "W" or "GLRD" please choose desired version.

8.2.7 Connection/connection size

R25	2.5...10	<input type="checkbox"/> G 3/4	<input type="checkbox"/> SAE 3/4	Nominal diameter 20
	12.5...20	<input type="checkbox"/> G 1	<input type="checkbox"/> SAE 1	Nominal diameter 25
R35	25...40	SAE 1.1/2		Nominal diameter 40
	50...80	SAE 2		Nominal diameter 50
R45	80...112	SAE 2		Nominal diameter 50
	125...200	SAE 2.1/2		Nominal diameter 65
R65	200...315	SAE 3		Nominal diameter 80
	400...630	SAE 4		Nominal diameter 100
R95	710...1120	F132 (Rickmeier standard)		Nominal diameter 132
	1250...1600	F160 (Rickmeier standard)		Nominal diameter 160
R105	1800...2400	DIN 200		Nominal diameter 200

→ For size R25, please select one type of connection (inch thread or SAE flange) for the corresponding displacement volume range!

→ If other connection types or sizes are desired, please contact us.

8.2.8 Direction of rotation (facing the shaft end)

<input type="checkbox"/> R	Clockwise
<input type="checkbox"/> L	Anti-clockwise
<input type="checkbox"/> C	<i>Clockwise/anti-clockwise rotation with changing direction of delivery</i>
<input type="checkbox"/> UNI	<i>Clockwise/anti-clockwise rotation with consistent direction of delivery (Size R35/R45/R65)</i>

→ Please select a direction of rotation version! With "UNI", the use of a reversing valve is required.

8.2.9 Materials

Casing	<input type="checkbox"/> EN-GJL-250 (GG-25)
	<input type="checkbox"/> <i>Alternative: EN-GJS-400-15 (GGG-40)</i>
Radial shaft seals	<input type="checkbox"/> NBR
	<input type="checkbox"/> FKM
	<input type="checkbox"/> <i>Alternative: HNBR, PTFE, EPDM, additional upon request</i>
Mechanical seal	<input type="checkbox"/> Hard carbon/SiC
	<input type="checkbox"/> <i>Alternative: various material combinations upon request</i>
O-rings	<input type="checkbox"/> NBR
	<input type="checkbox"/> FKM
	<input type="checkbox"/> <i>Alternative: HNBR, PTFE, EPDM, additional upon request</i>
Friction bearing	<input type="checkbox"/> Composite bearing type P10/DU
	<input type="checkbox"/> <i>Alternative: friction bearings free of ferrous and non-ferrous metals, additional upon request</i>

Coating	<input type="checkbox"/>	2-component paint, RAL 6011
	<input type="checkbox"/>	<i>Alternative: Various coating materials and structures available upon request</i>

→ Please select materials for housing, preselected shaft seal, O-rings, friction bearing and coating!
→ If other materials are desired, please contact us.

8.2.10 Additional options

<input type="checkbox"/>	<i>Attachment bearing/attachment bearing unit</i>	<i>For an increased radial load on the shaft journal</i>
<input type="checkbox"/>	<i>Double pump</i>	<i>Two pump stages (size R25/R35/R45)</i>
<input type="checkbox"/>	<i>Integrated heating</i>	<i>CCV version (size R35/R45)</i>
<input type="checkbox"/>	<i>Noise optimisation</i>	<i>For flow media with increased air content</i>

→ Please select additional, desired optional versions! For further information and/or the coordination of design details, please contact us.

Further information on pump selection:

8.3 Pump design

If you require a technical design from us or if you are planning for operation outside the limits specified in the following chapter, please send us the following data:

Desired flow rate (min.):	l/min
Speed:	
– Constant	rpm
– min./max.	rpm
Inlet pressure (manometric)	
– Constant	bar
– min./max.	bar
Outlet pressure (manometric)	
– Constant	bar
– min./max.	bar
Environmental temperature:	
– Constant	°C
– min./max.	°C
Flow media temperature:	
– Constant	°C
– min./max.	°C
Kinematic viscosity:	
– Constant	mm ² /s
– min./max.	mm ² /s
Flow medium:	

Further information on pump design:

9 Technical data

9.1 Operational limits

The maximum permissible operating conditions for gear pumps in the standard version are described in the following. Contact RICKMEIER whenever exceeding these specifications is necessary.

As a prerequisite for a long service life and maximum operational safety, the flow medium retains its lubricity and, if possible, is clean and non-corrosive, but is in any case free of hard admixtures.

Consideration must be given also to the following:

Properties		Min.	Max.
Flow medium	Kinematic viscosity	5 mm ² /s ¹⁾	20000 mm ² /s ¹⁾
	Degree of contamination (according to ISO 4406:1999, max.)		21/19/17
	Gas content (undissolved, max.)		10 vol. % ²⁾
	Temperature (NBR seals)	-25°C	80°C
	Temperature (FKM seals)	-25°C	150°C ³⁾
Inlet pressure (constant pressure according to DIN 24312)	Radial shaft seal, standstill ⁴⁾	-0.4 bar ⁵⁾	5 bar
	Radial shaft seal during operation ⁴⁾	-0.4 bar ⁵⁾	0.5 bar ⁶⁾
	Mechanical seal, standstill ⁴⁾	-0.4 bar ⁵⁾	10 bar
	Mechanical seal during operation ⁴⁾	-0.4 bar ⁵⁾	10 bar ⁷⁾

Table 8: Operational limits of the standard design

¹⁾ Depending on the application and operating conditions, lower and/or higher viscosities are possible, please contact us.

²⁾ Undissolved gas in the flow medium leads to increased noise emissions.

³⁾ If used above 80°C, special measures may be required under certain circumstances (e.g., heat-resistant clutch, pressure relief valve with heat-resistant spring, etc.); with optionally available sealing materials, different temperature ranges can be implemented.

⁴⁾ Manometric

⁵⁾ In the short term: -0.6 bar (e.g., during start-up)

⁶⁾ With optionally available radial shaft seal up to 6 bar

⁷⁾ With optionally available mechanical seal up to 25 bar

9.2 Operating data

Size	Delivery volume	Maximum approved operating data				Guide values		
		See legend ¹⁾				See legend ²⁾		
		Operating pressure ³⁾	Speed	Axial force ⁴⁾	Radial force ⁵⁾	Flow me- dium	Power require- ment	Sound pressure level ⁶⁾
V _g [cm ³]	p [bar]	n [1/min]	F _a [N]	F _r [N]	Q [dm ³ /min]	P [kW]	L _p (A) [dB(A)]	
R25	2.5	25	3600	90	30	3.4	0.05	54
	3.15					4.3	0.06	
	4					5.6	0.08	
	5					6.9	0.10	
	6.3					8.7	0.12	
	8					11.1	0.14	
	10	13.6	0.18					
	12.5	25	3600	90	330	17.6	0.21	59
	16					22.6	0.27	
	20					28.3	0.32	
R35	25	25	3600	200	500	33.4	0.46	63
	31.5					42.8	0.53	
	40					55.5	0.73	
	50	25	3600	200	1000	68.4	0.81	67
	63					87.1	1.1	
	80					108	1.2	
R45	80	25	3000	300	1150	110	1.4	69
	100					138	1.8	
	112					152	1.9	
	125	25	3000	300	1850	174	2.3	72
	160					228	2.9	
	180					246	3.0	
	200					273	3.3	
R65	200	25	2200	800	2000	276	3.8	75
	250					348	5.4	
	315					439	6.6	
	400	25	2200	800	4000	557	8.0	79
	500					696	10.1	
	630					871	13.7	
R95	710	25	1800	1500	7800	1023	17.0	85
	800					1161	21.5	
	900					1301	23.9	
	1000					1436	24.3	
	1120					1614	29.3	
	1250					25	1800	
	1400	2028	32.9					
	1600	2152	38.4					

Size	Delivery volume	Maximum approved operating data				Guide values		
		See legend ¹⁾				See legend ²⁾		
		Operating pressure ³⁾	Speed	Axial force ⁴⁾	Radial force ⁵⁾	Flow medium	Power requirement	Sound pressure level ⁶⁾
Vg [cm ³]	p [bar]	n [1/min]	Fa [N]	Fr [N]	Q [dm ³ /min]	P [kW]	Lp(A) [dB(A)]	
R105	1800	12	1600	1500	14000	2499	47.8	90
	2000					2779	53.2	
	2200					3060	58.5	
	2400					3343	63.8	

Table 9: Technical data of standard design

¹⁾ Speed = 1450 rpm, viscosity = 33 mm²/s

²⁾ Speed = 1450 rpm, viscosity = 33 mm²/s, operating pressure = 5 bar

³⁾ Avoid high operating pressures at low speed; cf. figure "Permitted pressure difference." Please contact us to determine the permissible minimum speed for your application.

⁴⁾ Axial force direction in the "clockwise" direction of rotation in the direction of the drive, "anti-clockwise" direction of rotation in the direction of the gear pump (right-hand drive pinion).

⁵⁾ Values apply to the version without an additional attachment bearing.

⁶⁾ The specified sound pressure level values apply to cavitation-free operation of the gear pump on the test stand (distance to the gear pump: 1 m).

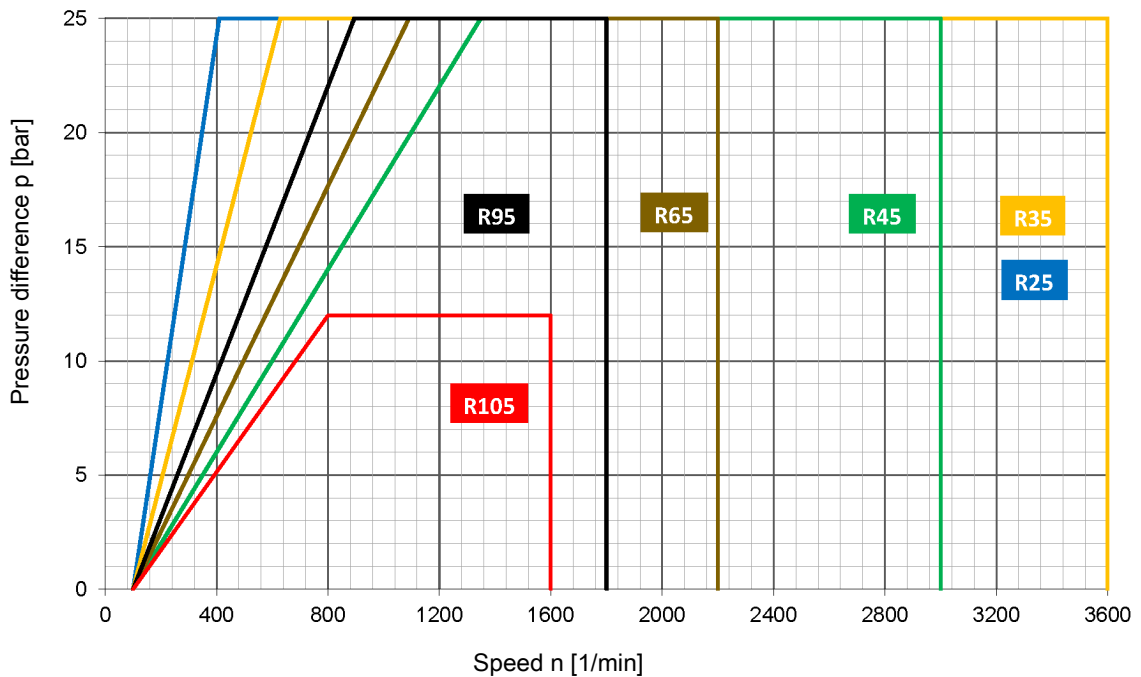

Illustration 13: Permissible pressure difference (viscosity = 33 mm²/s)

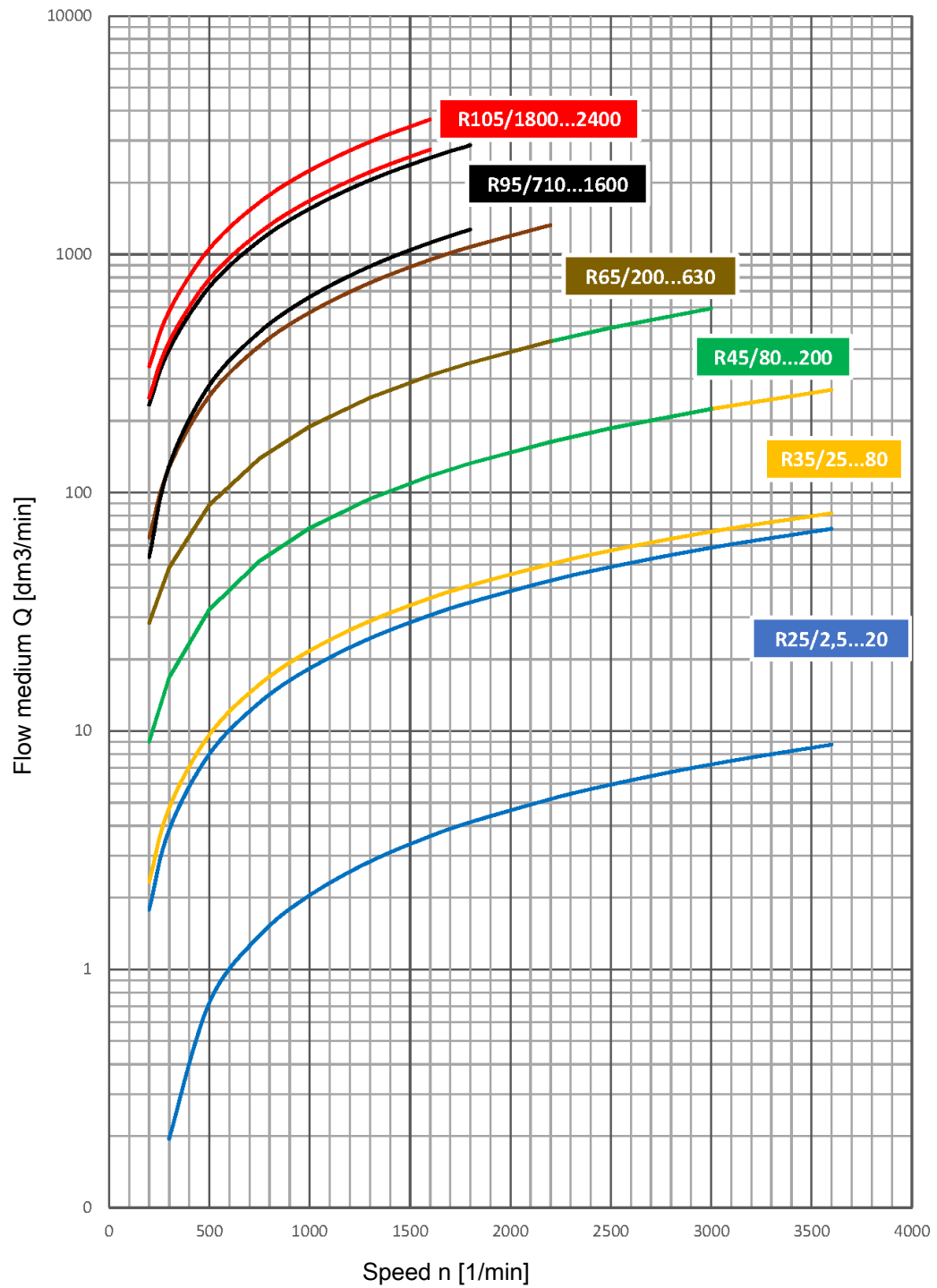

Illustration 14: Flow rate versus speed (values apply for kinematic viscosity = 100 mm²/s and outlet pressure p₂ = 12 bar)

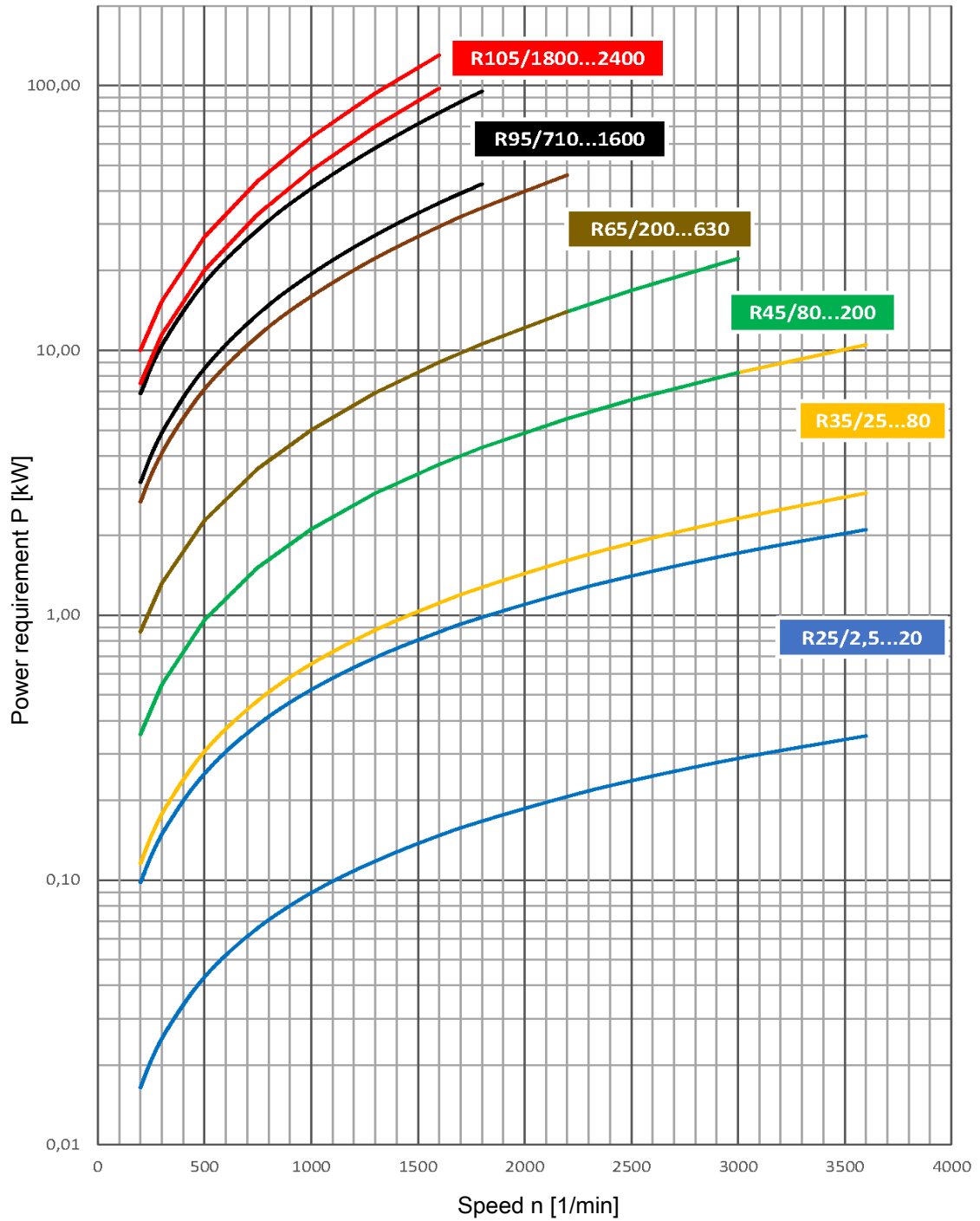

Illustration 15: Power requirement versus speed (values apply for kinematic viscosity = 100 mm²/s and outlet pressure p₂ = 12 bar)

10 Dimensional sheets of gear pumps

The following pages contain dimensions of the gear pumps in the basic version. If you have questions about the design or special designs, please contact us.

For dimensions and/or dimensional drawings of size R105, please contact us.

10.1 Size R25

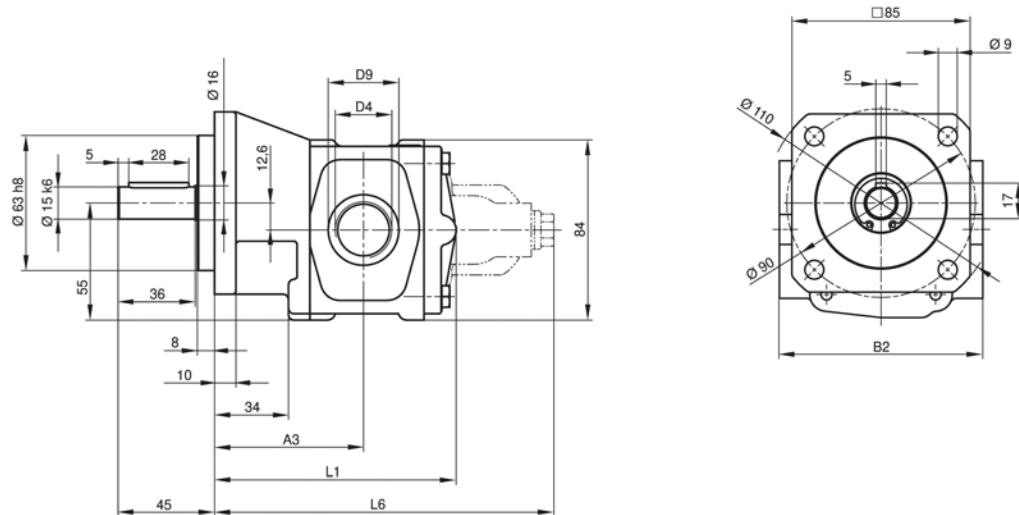

Option: pressure relief valve

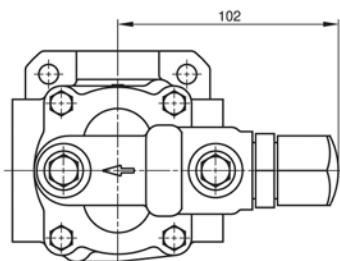

Option: SAE connection

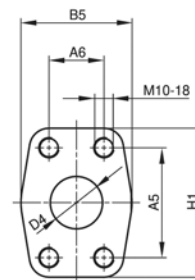

V_g [cm ³]	Suction and pressure connection									Additional Dimensions				Weight [kg]	
	Threaded connection			SAE connection						Flange size	A3	L1	L6	Stand-ard	Add. weight of DB
	B2	D4	D9	A5	A6	B2	B5	D4	H1						
2.5	97	G3/4	33-1	47.6	22.2	95	51	19	66	SAE3/4	69.5	114	159	4.0	0.8
3.15															
4															
5															
6.3															
8															
10															
12.5	97	G1	40-1	52.4	26.2	95	59	25	70	SAE1	74.5	141	186	4.8	0.8
16															
20															

Table 10: Dimensional sheet of size R25

10.2 Size R35

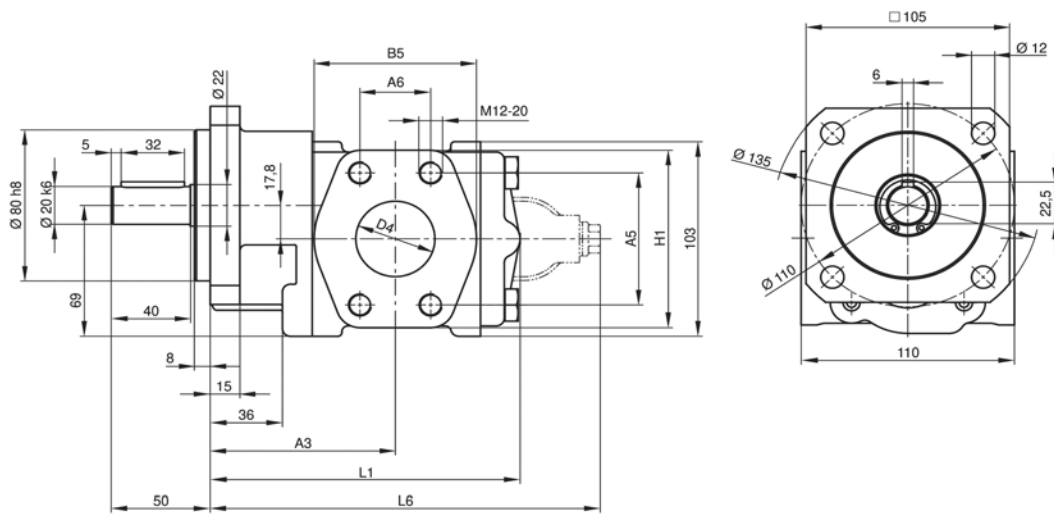

Option: pressure relief valve

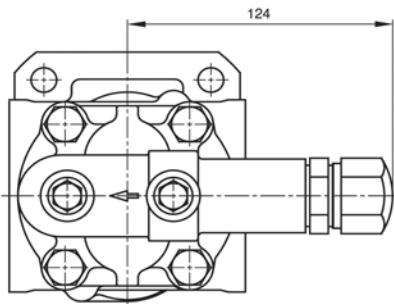

V_g [cm ³]	Suction and pressure connection					Flange size	Additional dimensions			Weight [kg]	
	A5	A6	B5	D4	H1		A3	L1	L6	Standard	Add. weight of DB
25	69.9	35.7	82	40	94	SAE1.1/2	93.5	157	197	7.4	0.7
31.5										7.5	
40										7.6	
50	77.8	42.9	97	50	102	SAE2	100.5	187	227	8.5	0.7
63										8.6	
80										8.7	

Table 11: Dimensional sheet of size R35

10.3 Size R45

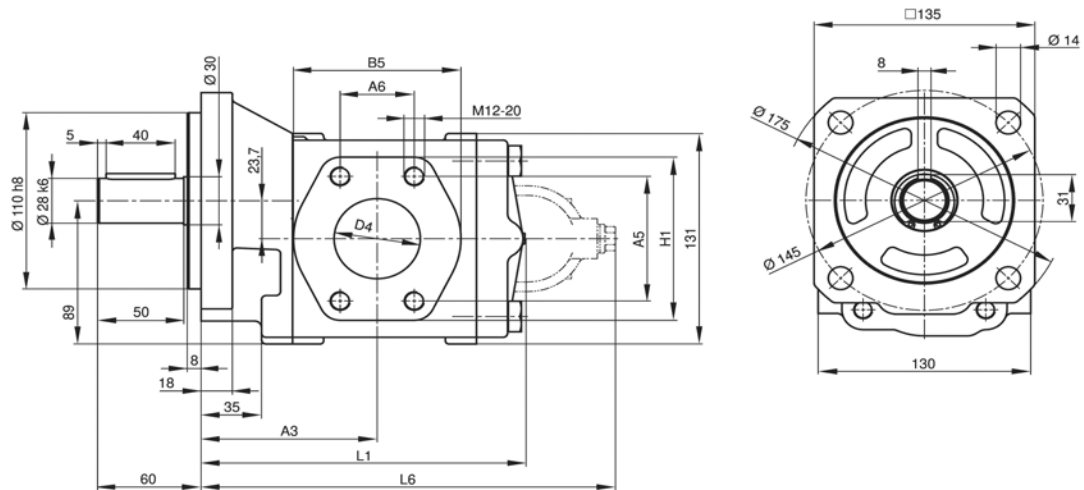

Option: pressure relief valve

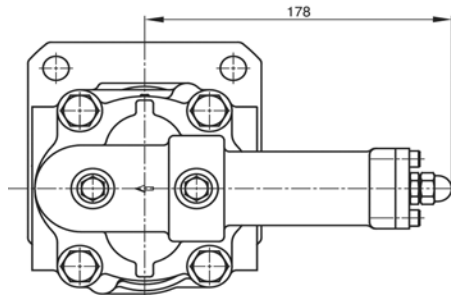

V_g [cm ³]	Suction and pressure connection					Flange size	Additional dimensions			Weight [kg]	
	A5	A6	B5	D4	H1		A3	L1	L6	Standard	Add. weight of DB
80	77.8	42.9	97	50	102	SAE2	102	187.5	240	13.7	1.3
100										13.9	
112										14.0	
125	88.9	50.8	109	63	115	SAE2.1/2	108	231.5	284	16.4	1.3
160										16.8	
180										17.0	
200										17.2	

Table 12: Dimensional sheet of size R45

10.4 Size R65

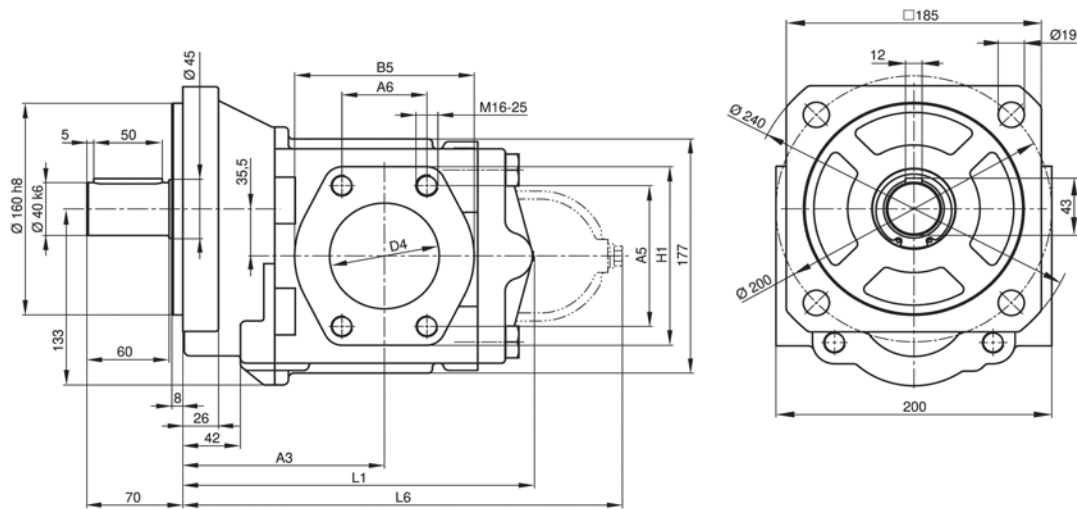

Option: pressure relief valve

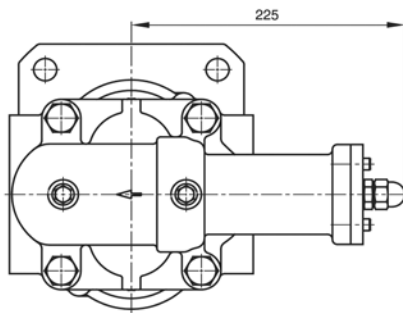

V_g [cm ³]	Suction and pressure connection						Additional dimensions			Weight [kg]	
	A5	A6	B5	D4	H1	Flange size	A3	L1	L6	Standard	Add. weight of DB
200	106.4	62	131	80	135	SAE3	147	256	321	35.5	3.6
250										36.0	
315										36.5	
400	130.2	77.8	152	102	162	SAE4	157	358	423	47.0	3.6
500										48.0	
630										49.0	

Table 13: Dimensional sheet of size R65

10.5 Size R95

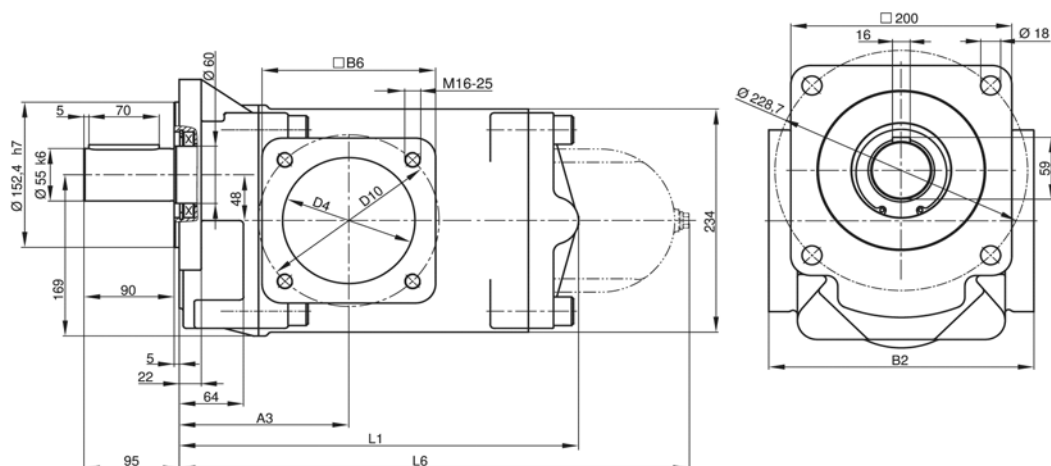

Option: pressure relief valve

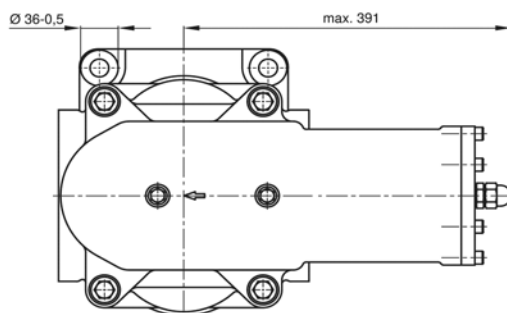

V _g [cm ³]	Suction and pressure connection					Additional dimensions			Weight [kg]	
	B2	B6	D4	D10	Flange size	A3	L1	L6	Standard	Add. weight of DB
710	240	173	132	180	DN132	169	400	514	83.0	31.6
800									84.0	
900									85.0	
1000									88.0	
1120									89.0	
1250	270	205	160	210	DN160	209	459	568	106.0	31.6
1400									108.0	
1600									110.0	

Table 14: Dimensional sheet of size R95

11 Dimensional sheets of pump units

Pump units are equipped as standard with three-phase asynchronous motors of efficiency class IE3. Single-phase AC motors and DC motors of various voltage levels are also available on request.

The motor dimensions specified in the dimension tables, which are not standardized in EN 50347, refer to our standard make (special manufacturers are available on request). The dimensions of the standard pump units for different motor sizes can be found in the tables on the following pages.

For different versions (e.g., other motor designs, gear pumps with pressure relief valve and/or mechanical seal), we will gladly inform you about the respective dimensions and weights on request.

For railway, ship or other applications with special vibration loads, we recommend the heavy-duty design for the unit foot. This changes the drilling pattern of the foot attachment; dimensions on request.

For dimensions and/or dimensional drawings of size R105, please contact us.

11.1 Size R25

11.1.1 Type IM B35

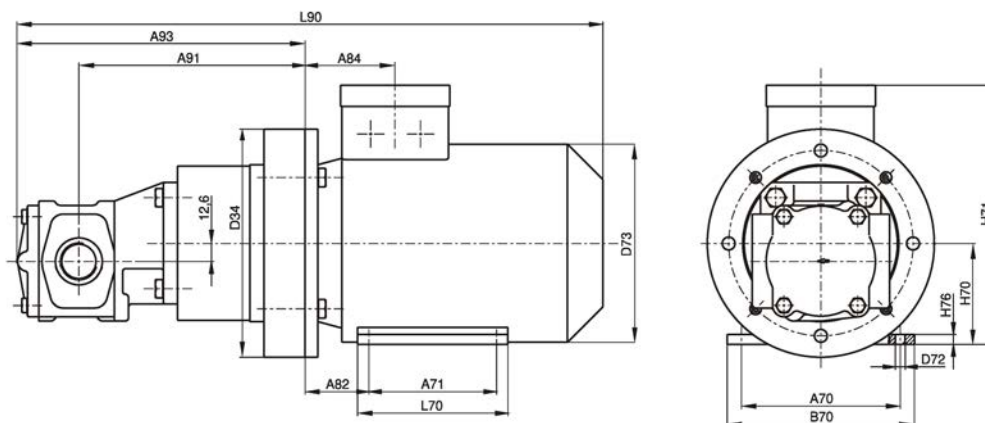

Size	Dimensions															
V_g [cm ³]	Motor	A70	A71	A82	A84	A91	A93	B70	D34	D72	D73	H70	H71	H76	L70	L90
2.5...10	71M	112	90	45	63.5	159.5	203.5	132	160	7	145	71	182	7	106	414
	80M ¹⁾	125	100	50	63.5	169.5	213.5	150	200	9.5	163	80	200	8	118	448
	90S	140	100	56	78.5	179.5	223.5	165	200	10	178	90	216	10	143	521
12.5...20	71M	112	90	45	63.5	164.5	231	132	160	7	145	71	182	7	106	441
	80M ¹⁾	125	100	50	63.5	174.5	241	150	200	9.8	163	80	200	8	118	475
	90S	140	100	56	78.5	184.5	251	165	200	10	178	90	216	10	143	548
	90L	140	125	56	78.5	184.5	251	165	200	10	178	90	216	10	143	548
	100L	160	140	63	96.5	198.5	265	196	250	12	198	100	266	12	176	601

Table 15: Dimensional sheet of size R25 - type IM B35

¹⁾ Values apply for IE1

11.1.2 Type IM B5 with unit foot

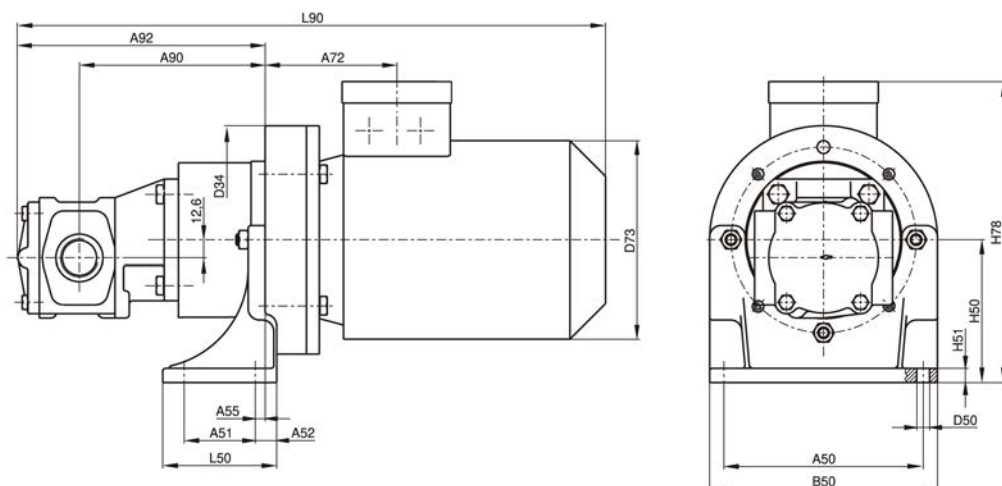

Size	Dimensions																
V_g [cm ³]	Motor	A50	A51	A52	A55	A72	A90	A92	B50	D34	D50	D73	H50	H51	H78	L50	L90
2.5...10	71M	140	50	15	7	76.5	146.5	190.5	160	160	9	145	100	10	211	80	414
	80M ¹⁾	180	60	15	4	79.5	153.5	197.5	210	200	11	163	112	12	232	90	448
	90S	180	60	15	4	94.5	163.5	207.5	210	200	11	178	112	12	238	90	521
12.5...20	71M	140	50	15	7	76.5	151.5	218	160	160	9	145	100	10	211	80	441
	80M ¹⁾	180	60	15	4	79.5	158.5	225	210	200	11	163	112	12	232	90	475
	90S	180	60	15	4	94.5	168.5	235	210	200	11	178	112	12	238	90	548
	90L	180	60	15	4	94.5	168.5	235	210	200	11	178	112	12	238	90	548
	100L	220	60	21	0	114.5	180.5	247	250	250	13	198	132	15	298	97	601

Table 16: Dimensional sheet of size R25 - type IM B5 with unit foot

¹⁾ Values apply for IE1

11.1.3 Type IM V1/B5

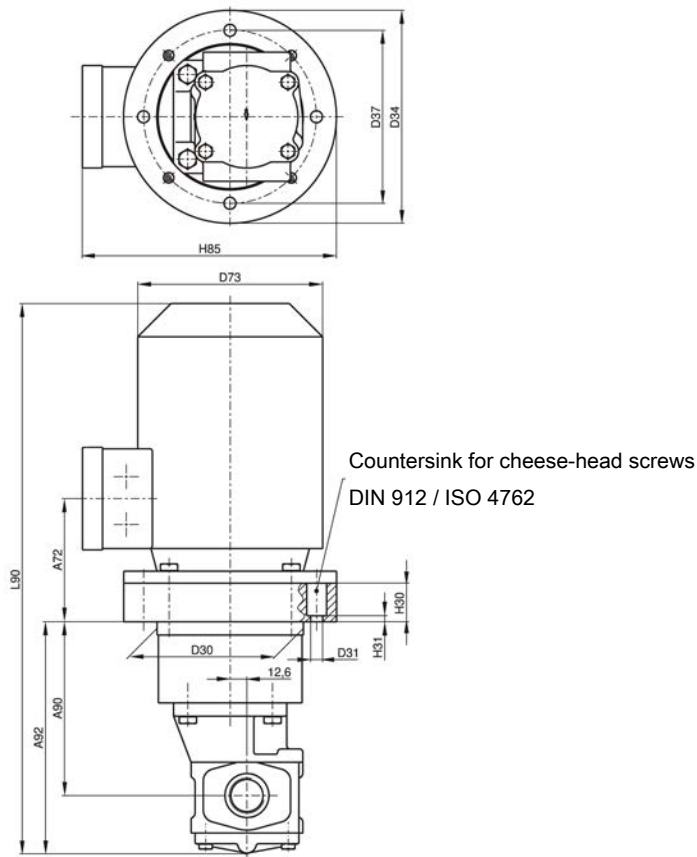

Size	Dimensions												
V_g [cm ³]	Motor	A72	A90	A92	D30	D31	D34	D37	D73	H30	H31	H85	L90
2.5...10	71M	76.5	146.5	190.5	110	9	160	130	145	13	4	191	414
	80M ¹⁾	79.5	153.5	197.5	145	11	200	165	163	16	5	220	448
	90S	94.5	163.5	207.5	145	11	200	165	178	16	5	226	521
12.5...20	71M	76.5	151.5	218	110	9	160	130	145	13	4	191	441
	80M ¹⁾	79.5	158.5	225	145	11	200	165	178	16	5	220	475
	90S	94.5	168.5	235	145	11	200	165	178	16	5	226	548
	90L	94.5	168.5	235	145	11	200	165	178	16	5	226	548
	100L	114.5	180.5	247	190	14	250	215	198	18	5	291	601

Table 17: Dimensional sheet of size R25 - type IM V1

¹⁾ Values apply for IE1

11.2 Size R35

11.2.1 Type IM B35

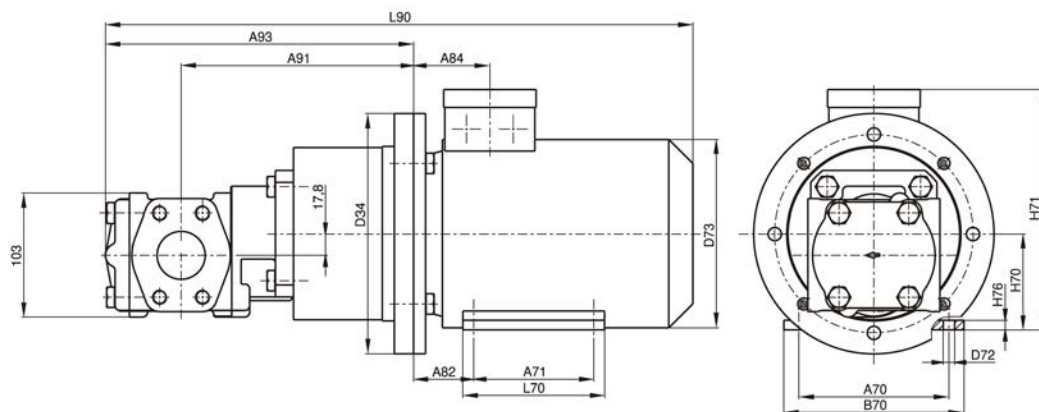

Size		Dimensions														
V_g [cm ³]	Motor	A70	A71	A82	A84	A91	A93	B70	D34	D72	D73	H70	H71	H76	L70	L90
25...40	71M	112	90	45	63.5	194.5	257.5	132	160	7	145	71	182	7	106	468
	80M ¹⁾	125	100	50	63.5	193.5	256.5	150	200	9.5	163	80	200	8	118	491
	90S	140	100	56	78.5	217.5	280.5	165	200	10	178	90	216	10	143	578
	90L	140	125	56	78.5	217.5	280.5	165	200	10	178	90	216	10	143	578
	100L	160	140	63	96.5	213.5	276.5	196	250	12	198	100	266	12	176	612
	112M	190	140	70	96	213.5	276.5	226	250	12	222	112	289	12	176	507
50...80	80M ¹⁾	125	100	50	63.5	200.5	286.5	150	200	9.5	163	80	200	8	118	521
	90S	140	100	56	78.5	224.5	310.5	165	200	10	178	90	216	10	143	608
	90L	140	125	56	78.5	224.5	310.5	165	200	10	178	90	216	10	143	608
	100L	160	140	63	96.5	220.5	306.5	196	250	12	198	100	266	12	176	642
	112M	190	140	70	96	220.5	306.5	226	250	12	222	112	289	12	176	636
	132S	216	140	89	115.5	255.5	341.5	256	300	12	262	132	334	15	218	727

Table 18: Dimensional sheet of size R35 - type IM B35

¹⁾ Values apply for IE1

11.2.2 Type IM B5 with unit foot

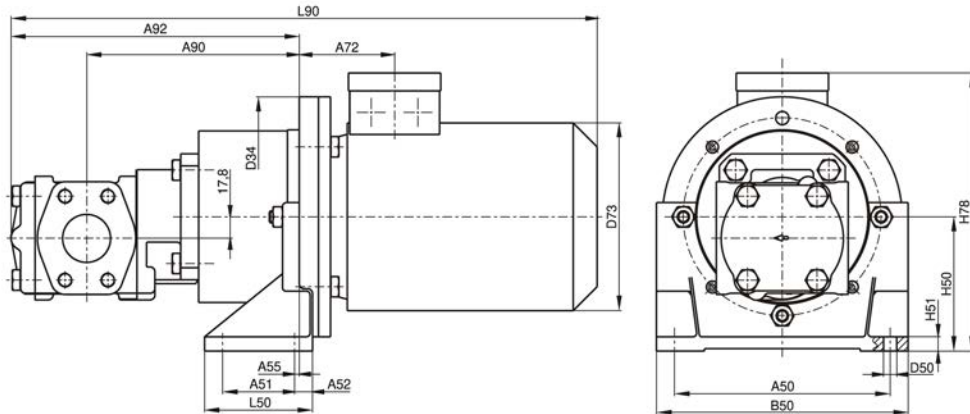

Size		Dimensions															
V_g [cm ³]	Motor	A50	A51	A52	A55	A72	A90	A92	B50	D34	D50	D73	H50	H51	H78	L50	L90
25...40	71M	140	50	15	7	76.5	181.5	244.5	160	160	9	145	100	10	211	80	468
	80M ¹⁾	180	60	15	4	79.5	177.5	240.5	210	200	11	163	112	12	232	90	491
	90S	180	60	15	4	94.5	201.5	264.5	210	200	11	178	112	12	238	90	578
	90L	180	60	15	4	94.5	201.5	264.5	210	200	11	178	112	12	238	90	578
	100L	220	60	21	0	115.5	194.5	257.5	250	250	13	198	132	15	298	97	612
	112M	220	60	21	0	115	194.5	257.5	250	250	13	222	132	15	309	97	606
50...80	80M ¹⁾	180	60	15	4	79.5	184.5	270.5	210	200	11	163	112	12	232	90	521
	90S	180	60	15	4	94.5	208.5	294.5	210	200	11	178	112	12	238	90	608
	90L	180	60	15	4	94.5	208.5	294.5	210	200	11	178	112	12	238	90	608
	100L	220	60	21	0	115.5	201.5	287.5	250	250	13	198	132	15	298	97	642
	112M	220	60	21	0	115	201.5	287.5	250	250	13	222	132	15	309	97	636
	132S	260	80	20	0	135.5	235.5	321.5	290	300	14	262	160	18	362	116	727

Table 19: Dimensional sheet of size R35 - type IM B5 with unit foot

¹⁾ Values apply for IE1

11.2.3 Type IM V1/B5

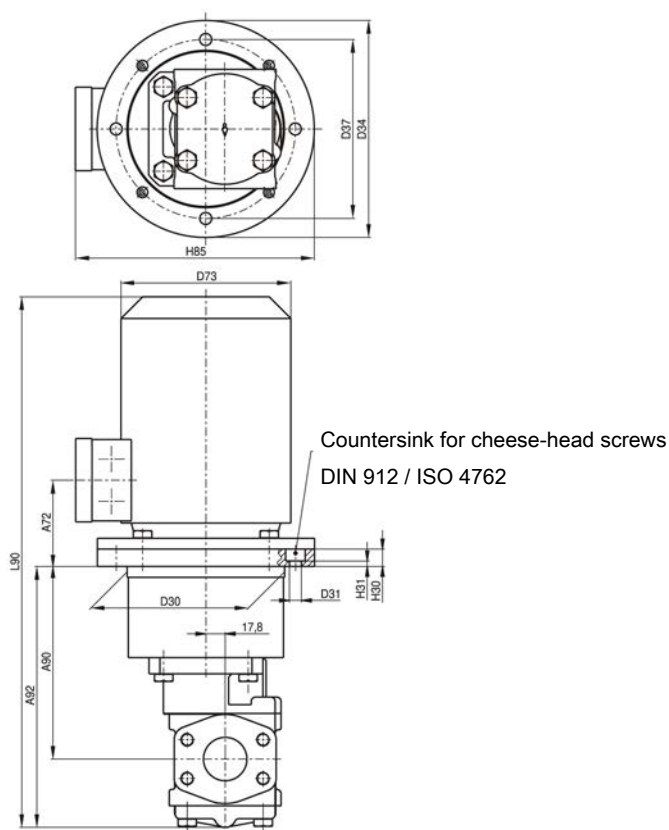

Size		Dimensions											
V_g [cm ³]	Motor	A72	A90	A92	D30	D31	D34	D37	D73	H30	H31	H85	L90
25...40	80M ¹⁾	79.5	177.5	240.5	145	11	200	165	163	16	5	220	491
	90S	94.5	201.5	264.5	145	11	200	165	178	16	5	226	578
	90L	94.5	201.5	264.5	145	11	200	165	178	16	5	226	578
	100L	115.5	194.5	257.5	190	14	250	215	198	19	6	291	612
	112M	115	194.5	257.5	190	14	250	215	222	19	6	302	606
50...80	80M ¹⁾	79.5	184.5	270.5	145	11	200	165	163	16	5	220	521
	90S	94.5	208.5	294.5	145	11	200	165	178	16	5	226	608
	90L	94.5	208.5	294.5	145	11	200	165	178	16	5	226	608
	100L	115.5	201.5	287.5	190	14	250	215	198	19	6	291	643
	112M	115	201.5	287.5	190	14	250	215	222	19	6	302	636
	132S	135.5	235.5	321.5	234	14	300	265	262	20	7	352	727

Table 20: Dimensional sheet of size R35 - type IM V1

¹⁾ Values apply for IE1

11.3 Size R45

11.3.1 Type IM B35

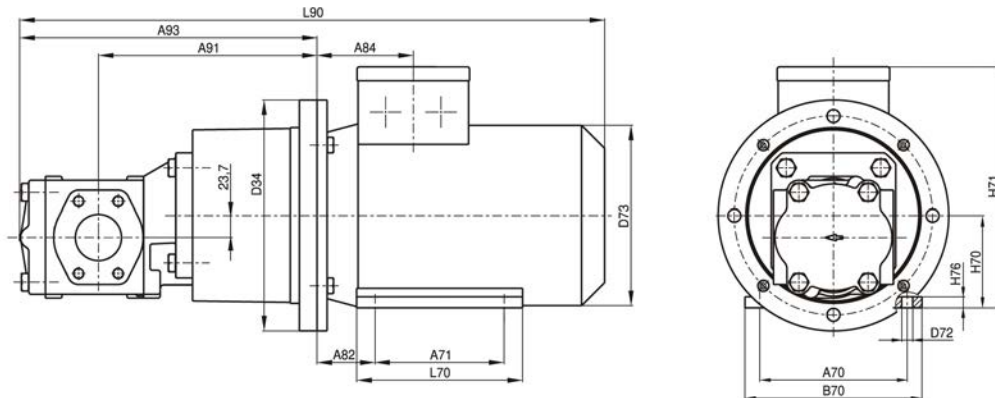

Size		Dimensions														
V_g [cm ³]	Motor	A70	A71	A82	A84	A91	A93	B70	D34	D72	D73	H70	H71	H76	L70	L90
80...112	90S	140	100	56	78.5	226	311.5	165	200	10	178	90	216	10	143	609
	90L	140	125	56	78.5	226	311.5	165	200	10	178	90	216	10	143	609
	100L	160	140	63	96.5	237	322.5	196	250	12	198	100	266	12	176	658
	112M	190	140	70	96	237	322.5	226	250	12	222	112	289	12	176	652
	132S	216	140	89	115.5	257	342.5	256	300	12	262	132	334	15	218	728
	132M	216	178	89	115.5	257	342.5	256	300	12	262	132	334	15	218	728
	160M	254	210	108	155	290	375.5	300	350	15	314	160	397	18	300	870
125...200	90L	140	125	56	78.5	232	355.5	165	200	10	178	90	216	10	143	653
	100L	160	140	63	96.5	243	366.5	196	250	12	198	100	266	12	176	702
	112M	190	140	70	96	243	366.5	226	250	12	222	112	289	12	176	696
	132S	216	140	89	115.5	263	386.5	256	300	12	262	132	334	15	218	772
	132M	216	178	89	115.5	263	386.5	256	300	12	262	132	334	15	218	772
	160M	254	210	108	155	296	419.5	300	350	15	314	160	397	18	300	914
	160L	254	254	108	155	296	419.5	300	350	15	314	160	397	18	300	914

Table 21: Dimensional sheet of size R45 - type IM B35

11.3.2 Type IM B5 with unit foot

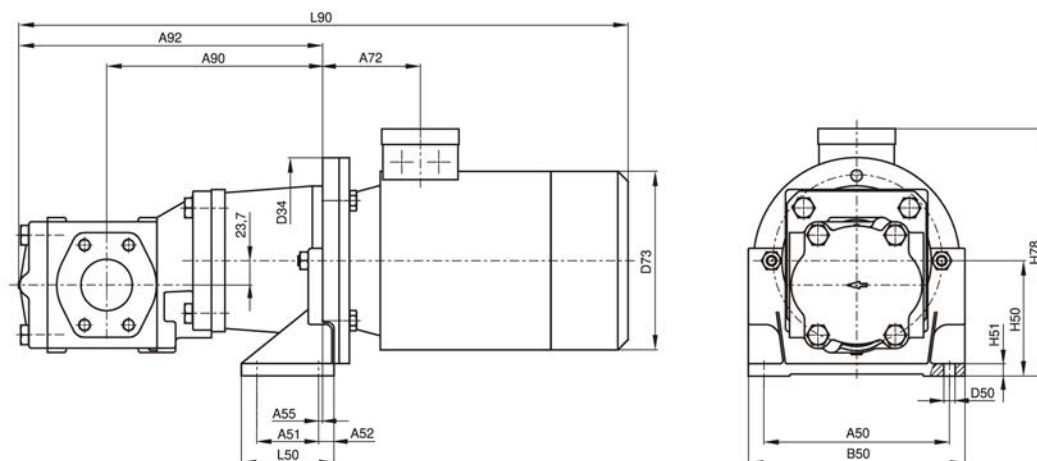

Size	Dimensions																
V_g [cm ³]	Motor	A50	A51	A52	A55	A72	A90	A92	B50	D34	D50	D73	H50	H51	H78	L50	L90
80...112	90S	180	60	15	4	94.5	210	295.5	210	200	11	178	112	12	238	90	609
	90L	180	60	15	4	94.5	210	295.5	210	200	11	178	112	12	238	90	609
	100L	220	60	21	0	114.5	219	304.5	250	250	13	198	132	15	298	97	658
	112M	220	60	21	0	114	219	304.5	250	250	13	222	132	15	309	97	652
	132S	260	80	20	0	135.5	237	322.5	290	300	14	262	160	18	362	116	728
	132M	260	80	20	0	135.5	237	322.5	290	300	14	262	160	18	362	116	728
	160M	300	110	20	0	181	264	349.5	340	350	18	314	180	22	417	150	870
125...200	90L	180	60	15	4	94.5	216	339.5	210	200	11	178	112	12	238	90	653
	100L	220	60	21	0	114.5	225	348.5	250	250	13	198	132	15	298	97	702
	112M	220	60	21	0	114	225	348.5	250	250	13	222	132	15	309	97	696
	132S	260	80	20	0	135.5	243	366.5	290	300	14	262	160	18	362	116	772
	132M	260	80	20	0	135.5	243	366.5	290	300	14	262	160	18	362	116	772
	160M	300	110	20	0	181	270	393.5	340	350	18	314	180	22	417	150	914
	160L	300	110	20	0	181	270	393.5	340	350	18	314	180	22	417	150	914

Table 22: Dimensional sheet of size R45 - type IM B5 with unit foot

11.3.3 Type IM V1/B5

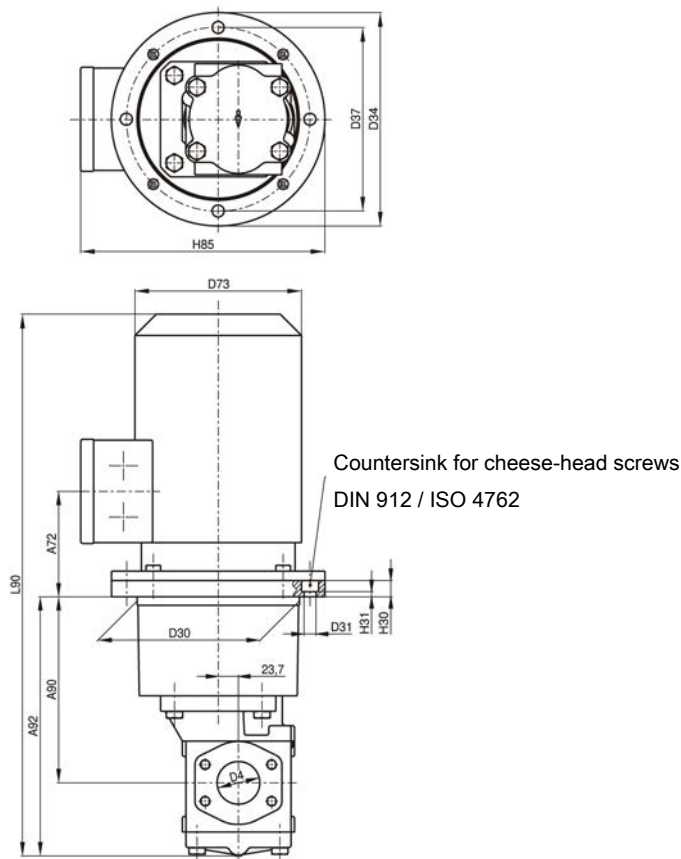

Size	Dimensions												
V_g [cm ³]	Motor	A72	A90	A92	D30	D31	D34	D37	D73	H30	H31	H85	L90
80...112	100L	114.5	219	304.5	190	14	250	215	198	18	5	291	658
	112M	114	219	304.5	190	14	250	215	222	18	5	302	652
	132S	135.5	237	322.5	234	14	300	265	262	20	7	352	728
	132M	135.5	237	322.5	234	14	300	265	262	20	7	352	728
	160M	181	264	349.5	260	18	350	300	314	26	8.5	412	870
125...200	100L	114.5	225	348.5	190	14	250	215	198	18	5	291	702
	112M	114	225	348.5	190	14	250	215	222	18	5	302	696
	132S	135.5	243	366.5	234	14	300	265	262	20	7	352	772
	132M	135.5	243	366.5	234	14	300	265	262	20	7	352	772
	160M	181	270	393.5	260	18	350	300	314	26	8.5	412	914
	160L	181	270	393.5	260	18	350	300	314	26	8.5	412	914

Table 23: Dimensional sheet of size R45 - type IM V1/B5

11.4 Size R65

11.4.1 Type IM B35

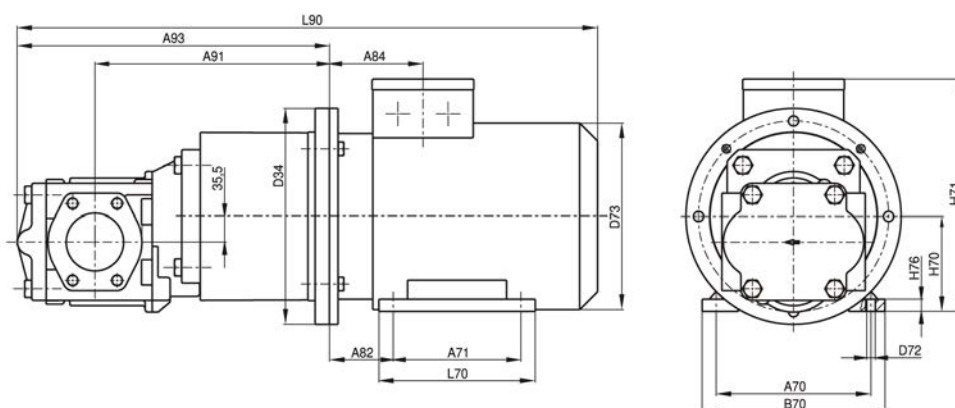

Size		Dimensions														
V_g [cm ³]	Motor	A70	A71	A82	A84	A91	A93	B70	D34	D72	D73	H70	H71	H76	L70	L90
200...315	132S	216	140	89	115.5	315	424	256	300	12	262	132	334	15	218	809
	132M	216	178	89	115.5	315	424	256	300	12	262	132	334	15	218	809
	160M	254	210	108	155	351	460	300	350	15	314	160	397	18	300	954
	160L	254	254	108	155	351	460	300	350	15	314	160	397	18	300	954
	180M	279	241	120.5	155	351	460	339	350	15	356	180	466	20	328	1018
	180L	279	279	120.5	155	351	460	339	350	15	356	180	466	20	328	1048
	200L	318	305	133	164	351	460	378	400	19	396	200	515	25	355	1096
400...630	132S	216	140	89	115.5	325	526	256	300	12	262	132	334	15	218	911
	132M	216	178	89	115.5	325	526	256	300	12	262	132	334	15	218	911
	160M	254	210	108	155	361	562	300	350	15	314	160	397	18	300	1056
	160L	254	254	108	155	361	562	300	350	15	314	160	397	18	300	1056
	180M	279	241	120.5	155	361	562	339	350	15	356	180	466	20	328	1120
	180L	279	279	120.5	155	361	562	339	350	15	356	180	466	20	328	1150
	200L	318	305	133	164	361	562	378	400	19	396	200	515	25	355	1198
	225S	356	286	149	164	391	592	436	450	19	449	225	563	34	361	1240
	225M	356	311	149	164	391	592	436	450	19	449	225	563	34	361	1300
250M	406	349	168	192	405	606	490	550	24	497	250	660	40	409	1353	

Table 24: Dimensional sheet of size R65 - type IM B35

11.4.2 Type IM B5 with unit foot

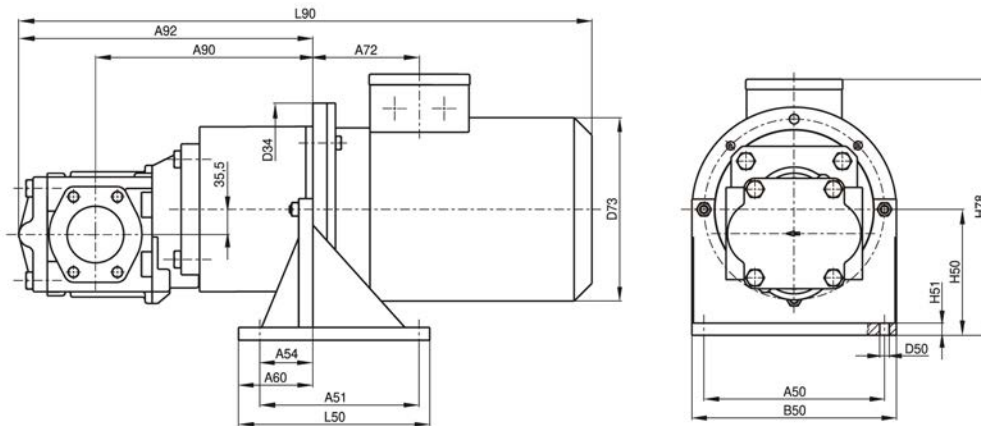

Size		Dimensions															
V_g [cm ³]	Motor	A50	A51	A54	A60	A72	A90	A92	B50	D34	D50	D73	H50	H51	H78	L50	L90
200...315	132S	265	225	75	105	135.5	195	404	300	300	14	262	185	18	387	270	809
	132M	265	225	75	105	135.5	295	404	300	300	14	262	185	18	387	270	809
	160M	300	265	90	110	181	325	434	350	350	18	314	235	18	472	305	954
	160L	300	265	90	110	181	325	434	350	350	18	314	235	18	472	305	954
	180M	300	265	90	110	181	325	434	350	350	18	356	235	18	521	305	1018
	180L	300	265	90	110	181	325	434	350	350	18	356	235	18	521	305	1048
	200L	350	300	100	125	190	325	434	407	400	18	396	260	20	575	350	1096
400...630	132S	265	225	75	105	135.5	305	506	300	300	14	262	185	18	387	270	911
	132M	265	225	75	105	135.5	305	506	300	300	14	262	185	18	387	270	911
	160M	300	265	90	110	181	335	536	350	350	18	314	235	18	472	305	1056
	160L	300	265	90	110	181	335	536	350	350	18	314	235	18	472	305	1056
	180M	300	265	90	110	181	335	536	350	350	18	356	235	18	521	305	1120
	180L	300	265	90	110	181	335	536	350	350	18	356	235	18	521	305	1150
	200L	350	300	100	125	190	335	536	407	400	18	396	260	20	575	350	1198
	225S	400	335	110	138	190	365	566	458	450	18	449	295	20	633	385	1240
	225M	400	335	110	138	190	365	566	458	450	18	449	295	20	633	385	1300
250M	500	415	140	165	218	379	580	550	550	18	497	350	25	760	465	1353	

Table 25: Dimensional sheet of size R65 - type IM B5 with unit foot

11.4.3 Type IM V1/B5

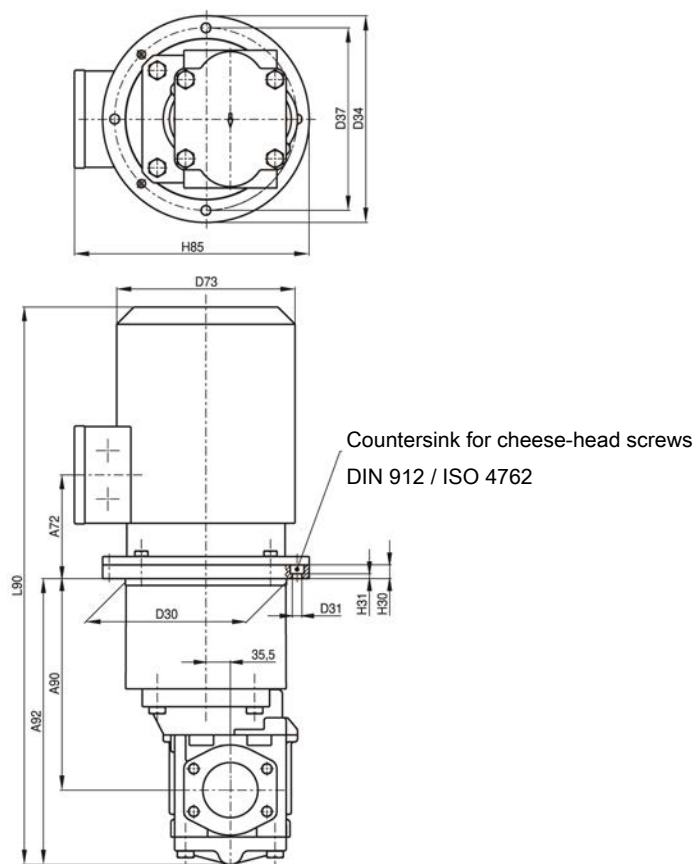

Size		Dimensions											
V_g [cm ³]	Motor	A72	A90	A92	D30	D31	D34	D37	D73	H30	H31	H85	L90
200...315	132S	135.5	295	404	234	14	300	265	262	20	5	352	809
	132M	135.5	295	404	234	14	300	265	262	20	5	352	809
	160M	181	325	434	260	18	350	300	314	26	7	412	954
	160L	181	325	434	260	18	350	300	314	26	7	412	954
	180M	181	325	434	260	18	350	300	356	26	7	461	1018
	180L	181	325	434	260	18	350	300	356	26	7	461	1048
	200L	190	325	434	300	18	400	350	396	26	8.5	515	1096
400...630	132S	135.5	305	234	14	300	265	262	20	5	5	352	911
	132M	135.5	305	234	14	300	265	262	20	5	5	352	911
	160M	181	335	260	18	350	300	314	26	7	7	412	1056
	160L	181	335	260	18	350	300	314	26	7	7	412	1056
	180M	181	335	260	18	350	300	356	26	7	7	461	1120
	180L	181	335	260	18	350	300	356	26	7	7	461	1150
	200L	190	335	300	18	400	350	396	26	8.5	8.5	515	1198
	225S	190	365	350	18	450	400	449	26	8.5	8.5	563	1240
	225M	190	365	350	18	450	400	449	26	8.5	8.5	563	1300
	250M	218	379	450	18	550	500	497	26	8.5	8.5	685	1353

Table 26: Dimensional sheet of size R65 - type IM V1/B5

11.5 Size R95

11.5.1 Type IM B35

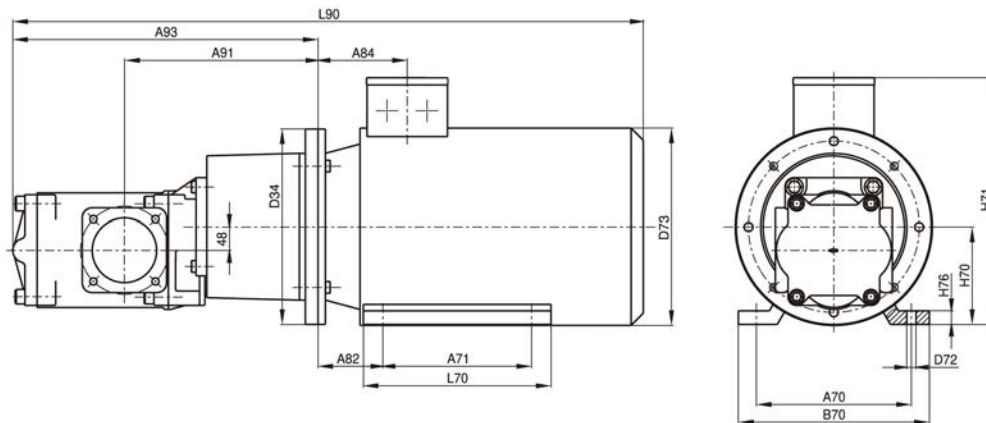

Size	Dimensions															
V_g [cm ³]	Motor	A70	A71	A82	A84	A91	A93	B70	D34	D72	D73	H70	H71	H76	L70	L90
710...1120	160M	254	210	108	155	425	656	300	350	15	314	160	397	18	300	1150
	160L	254	254	108	155	425	656	300	350	15	314	160	397	18	300	1150
	180M	279	241	120.5	155	425	656	339	350	15	356	180	466	20	328	1214
	180L	279	279	120.5	155	425	656	339	350	15	356	180	466	20	328	1244
	200L	318	305	133	164	397	628	378	400	19	396	200	515	25	355	1264
	225S	356	286	149	164	431	662	436	450	19	449	225	563	34	361	1310
	225M	356	311	149	164	431	662	436	450	19	449	225	563	34	361	1370
	250M	406	349	168	192	434	665	490	550	24	497	250	660	40	409	1412
	280S	457	368	190	210	434	665	540	550	24	551	280	713	40	479	1485
280M	457	419	190	210	434	665	540	550	24	551	280	713	40	479	1595	
1250...1600	200L	318	305	133	164	437	687	378	400	19	396	200	515	25	355	1323
	225S	356	286	149	164	471	721	436	450	19	449	225	563	34	361	1369
	225M	356	311	149	164	471	721	436	450	19	449	225	563	34	361	1429
	250M	406	349	168	192	474	724	490	550	24	497	250	660	40	409	1471
	280S	457	368	190	210	474	724	540	550	24	551	280	713	40	479	1544
	280M	457	419	190	210	474	724	540	550	24	551	280	713	40	479	1654
	315S	508	406	216	238	519	769	610	660	28	616	315	830	50	527	1681
	315M	508	457	216	238	519	769	610	660	28	616	315	830	50	578	1846

Table 27: Dimensional sheet of size R95 - type IM B35

11.5.2 Type IM B5 with unit foot

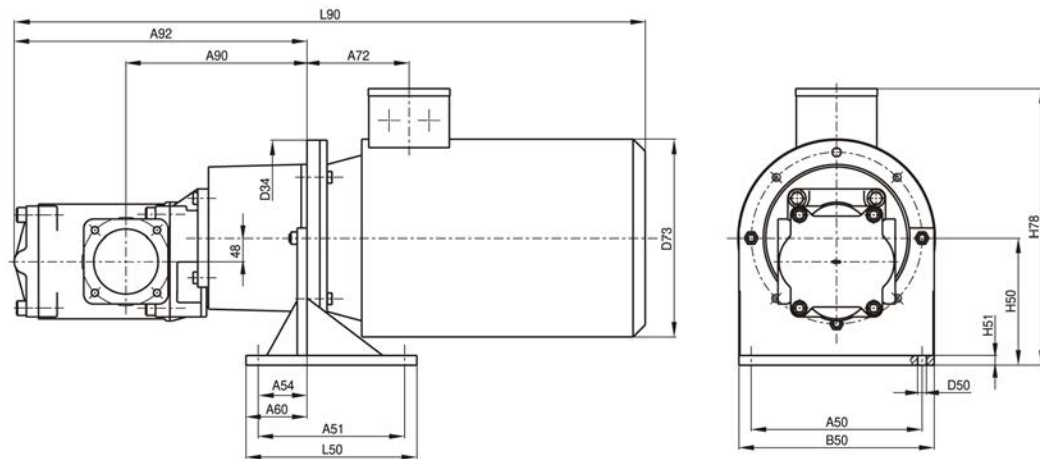

Size	Dimensions																
V_g [cm ³]	Motor	A50	A51	A54	A60	A72	A90	A92	B50	D34	D50	D73	H50	H51	H78	L50	L90
710...1120	160M	300	265	90	110	181	399	630	350	350	18	314	235	18	472	305	1150
	160L	300	265	90	110	181	399	630	350	350	18	314	235	18	472	305	1150
	180M	300	265	90	110	181	399	630	350	350	18	356	235	18	521	305	1214
	180L	300	265	90	110	181	399	630	350	350	18	356	235	18	521	305	1244
	200L	350	300	100	125	190	371	602	407	400	18	396	260	20	575	350	1264
	225S	400	335	110	138	190	405	636	458	450	18	449	295	20	633	385	1310
	225M	400	335	110	138	190	405	636	458	450	18	449	295	20	633	385	1370
	250M	500	415	140	165	218	408	639	550	550	18	497	350	25	760	465	1412
	280S	500	415	140	165	236	408	639	550	550	18	551	350	25	783	465	1485
280M	500	415	140	165	236	408	639	550	550	18	551	350	25	783	465	1595	
1250...1600	200L	350	300	100	125	190	411	661	407	400	18	396	260	20	575	350	1323
	225S	400	335	110	138	190	445	695	458	450	18	449	295	20	633	385	1369
	225M	400	335	110	138	190	445	695	458	450	18	449	295	20	633	385	1429
	250M	500	415	140	165	218	448	698	550	550	18	497	350	25	760	465	1471
	280S	500	415	140	165	236	448	698	550	550	18	551	350	25	783	465	1544
	280M	500	415	140	165	236	448	698	550	550	18	551	350	25	783	465	1654
	315S	600	495	165	195	270	487	737	660	660	22	616	380	30	895	550	1681
	315M	600	495	165	195	270	487	737	660	660	22	616	380	30	895	550	1846

Table 28: Dimensional sheet of size R95 - type IM B5 with unit foot

11.5.3 Type IM V1/B5

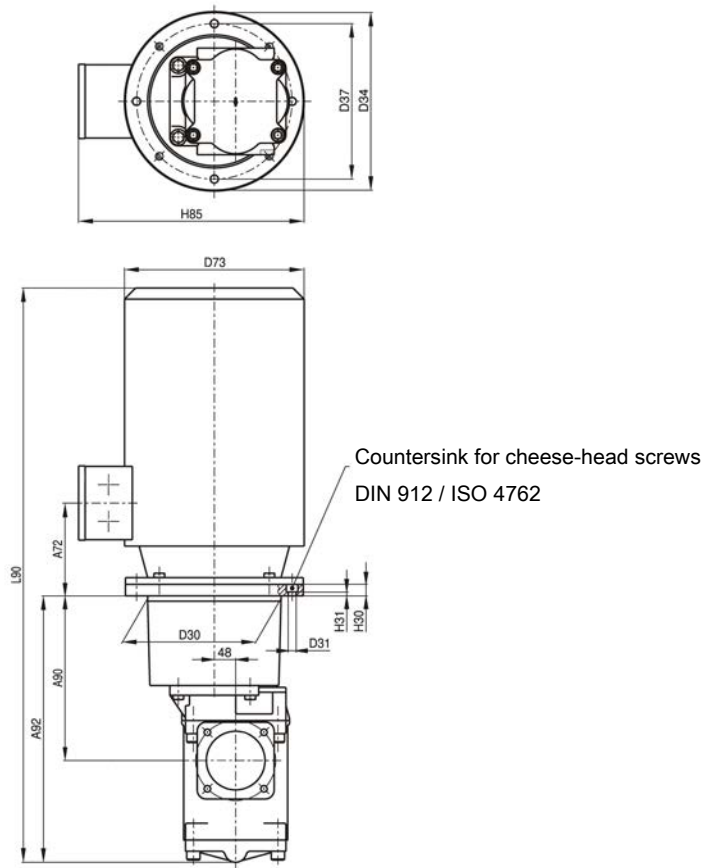

Size	Dimensions												
V_g [cm ³]	Motor	A72	A90	A92	D30	D31	D34	D37	D73	H30	H31	H85	L90
710...1120	160M	181	399	630	260	18	350	300	314	26	7	412	1150
	160L	181	399	630	260	18	350	300	314	26	7	412	1150
	180M	181	399	630	260	18	350	300	356	26	7	461	1214
	180L	181	399	630	260	18	350	300	356	26	7	461	1244
	200L	190	371	602	300	18	400	350	396	26	8.5	515	1264
	225S	190	405	636	350	18	450	400	449	26	8.5	563	1310
	225M	190	405	636	350	18	450	400	449	26	8.5	563	1370
	250M	218	408	639	450	18	550	500	497	26	8.5	685	1412
	280S	236	408	639	450	18	550	500	551	26	8.5	708	1485
	280M	236	408	639	450	18	550	500	551	26	8.5	708	1595
1250...1600	200L	190	411	661	300	18	400	350	396	26	8.5	515	1323
	225S	190	445	695	350	18	450	400	449	26	8.5	563	1369
	225M	190	445	695	350	18	450	400	449	26	8.5	563	1429
	250M	218	448	698	450	18	550	500	497	26	8.5	685	1471
	280S	236	448	698	450	18	550	500	551	26	8.5	708	1544
	280M	236	448	698	450	18	550	500	551	26	8.5	708	1654
	315S	270	487	737	550	22	660	600	616	32	10.5	845	1681
	315M	270	487	737	550	22	660	600	616	32	10.5	845	1846

Table 29: Dimensional sheet of size R95 - type IM V1/B5